

Video inserter

CI-RL4-SC15

**Compatible with Volvo vehicles with
Sensus Connect infotainment
and 8.7inch touch-monitor**



example

**Video-inserter for rear-view camera
and two more video inputs**

Product features

- Video-inserter for factory-infotainment systems
- 1 CVBS Input for rear-view camera
- 1 CVBS Input for front camera
- 2 CVBS Video-inputs for after-market Video sources (e.g. USB-Player, DVB-T Tuner)
- Automatic switching to rear-view camera input on engagement of the reverse gear
- Automatic front camera switching after reverse gear for 10 seconds
- Video-in-motion (ONLY for connected video-sources)
- Video-inputs NTSC compatible

Contents

1. Prior to installation

- 1.1. Delivery contents
- 1.2. Checking the compatibility of vehicle and accessories
- 1.3. Boxes and connectors – video interface
- 1.4. Settings of the 8 Dip switches (black)
 - 1.4.1. Activating the front camera (dip 1)
 - 1.4.2. Enabling the interface's video inputs (dip 2-3)
 - 1.4.3. Rear-view camera setting (dip 5)
 - 1.4.4. Front camera activation type (Dip 6)
 - 1.4.5. Video representation
- 1.5. Settings of the 4 Dip switches (CAN function – red)

2. Installation

- 2.1. Place of connection
- 2.2. Connection schema
- 2.3. Connection - picture signal cable
- 2.4. Connection – 10pin Power / CAN cable
- 2.5. Analog power supply for the video interface
- 2.6. Power supply output
- 2.7. Connection - video-sources
 - 2.7.1. Audio insertion
 - 2.7.2. After-market front camera
 - 2.7.3. After-market rear-view camera
 - 2.7.3.1. Case 1: Interface receives the reverse gear signal
 - 2.7.3.2. Case 2: Interface does not receive the reverse gear signal
- 2.8. Connection - video-interface and external keypad
- 2.9. Picture settings

3. Interface operation

- 3.1. By factory infotainment button
- 3.2. By external keypad

4. Specifications

5. FAQ – Trouble Shooting-Interface functions

Legal Information

By law, watching moving pictures while driving is prohibited, the driver must not be distracted. We do not accept any liability for material damage or personal injury resulting, directly or indirectly, from installation or operation of this product. Apart from using this product in an unmoved vehicle, it should only be used to display fixed menus or rear-view-camera video when the vehicle is moving (for example the MP3 menu for DVD upgrades).

Changes/updates of the vehicle's software can cause malfunctions of the interface. Up to one year after purchase we offer free software-updates for our interfaces. To receive a free update, the interface has to be sent in at own cost. Wages for de-and reinstallation and other expenditures involved with the software-updates will not be refunded.

1. Prior to installation

Read the manual prior to installation. Technical knowledge is necessary for installation. The video interface's place of installation must be free of moisture and away from heat sources.

Before the final installation in the vehicle of the video sources, we recommend a test-run to ensure the compatibility of vehicle and interface. Due to changes in the production of the vehicle manufacturer there's always a possibility of incompatibility.

1.1. Delivery contents

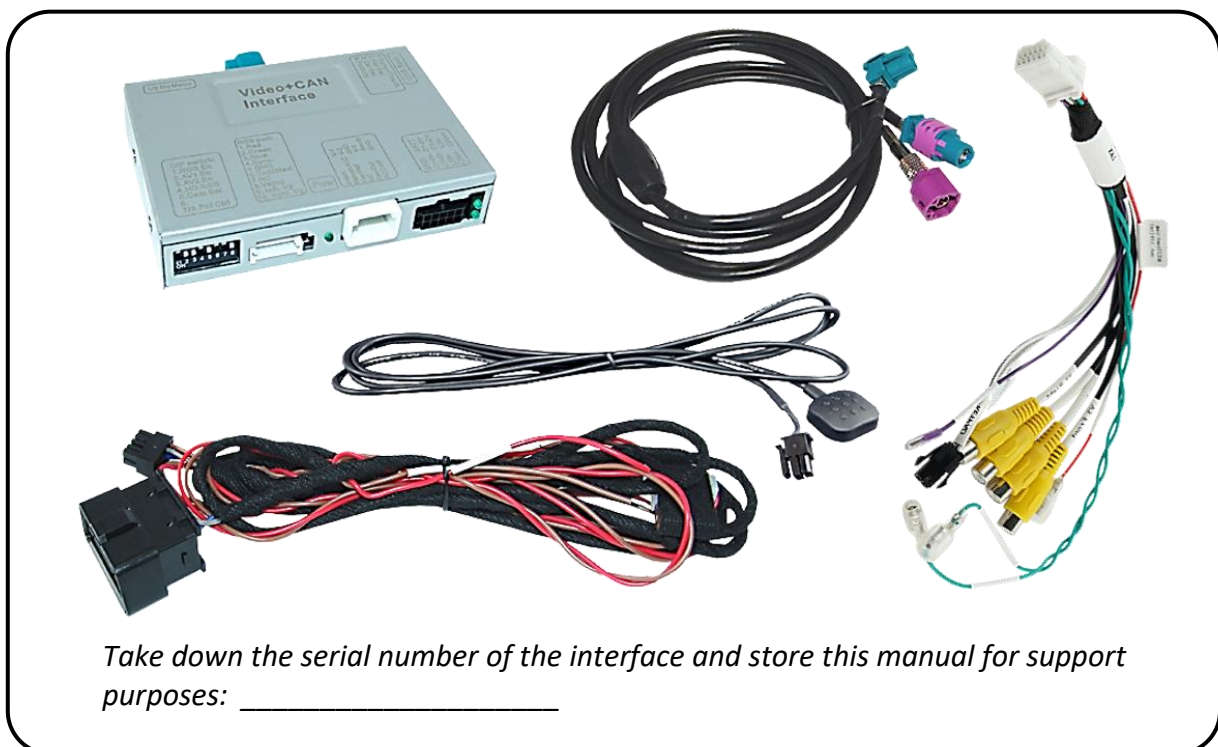

1.2. Checking the compatibility of vehicle and accessories

Compatibility		
Brand	Compatible vehicles	Compatible systems
Volvo	S60 model years 2020 until 2021, S90 model years 2017 until 2021, V60 model years 2016 until 2021, V90 model years 2016 until 2021, XC40 model years 2019 until 2021, XC60 model years 2018 until 2021, XC90 model years 2015 until 2021	Sensus Connect with 8,7" monitor <i>Not compatible with vehicles with Google navigation since model year 2022</i>

Limitations	
<i>Google navigation</i>	Not compatible with vehicles with Google navigation since model year 2022.
<i>Video only</i>	The interface inserts ONLY video signals into the infotainment. For inserting Audio signals either the possibly existing factory audio-AUX-input or a FM-modulator can be used. If 2 audio sources shall be connected to the infotainment, an additional electronic is necessary to switch them.
<i>After market front camera</i>	The front camera will automatically be switched for 10 seconds after disengaging the reverse gear. A manually front camera switching is possible by external keypad.
<i>Video input signal</i>	NTSC video sources compatible only

1.3. Boxes and connectors – video interface

The video-interface converts the connected after-market sources video signals into a LVDS signal which is inserted in the factory monitor using separate trigger options. Further it reads the vehicle's digital signals out of the vehicle's CAN-bus and converts them for the video interface.

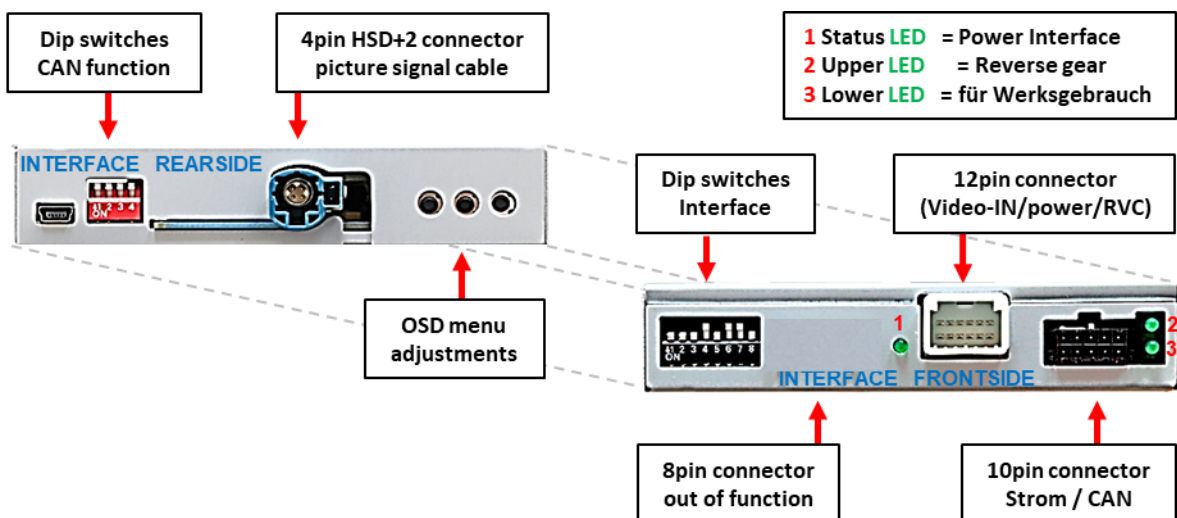

1.4. Settings of the 8 Dip switches (black)

Some settings have to be selected by the dip-switches on the video interface. Dip position down is ON and position up is OFF.



Dip	Function	ON (down)	OFF (up)
1	Front camera	enabled*	disabled
	Power supply output (red wire)	+12V (max. 3A) when reverse gear is engaged incl. 10 seconds delay and +12V by manual switching to front camera by keypad	+12V (max. 3A) ACC
2	CVBS AV1-input	enabled	disabled
3	CVBS AV2-input	enabled	disabled
4	No function		set to OFF
5	Rear-view cam type	after-market	factory or none
6	Type of front camera activation	for 10 seconds after disengaging the reverse gear and manually by keypad	only manually by keypad
7	Video representation	big size picture	small size picture
8	No function		set to OFF

*The front camera **will only be switched automatically** for 10 seconds after disengaging the reverse gear, **if dip6 is also set to ON** (see following information).

After each Dip-switch-change a power-reset of the Video Interface has to be performed!

See the following chapters for detailed information.

1.4.1. Activating the front camera (dip 1)

If set to **ON**, the interface switches for 10 seconds from the rear-view camera to the front camera input after having disengaged the reverse gear. In addition, a manual switch-over to the front camera input is possible via keypad (short press) from any image mode. The selection of automatic or manual front camera switching is controlled by dip6. Description of the front camera Power supply: see chapter "Power supply output".

1.4.2. Enabling the interface's video inputs (dip 2-3)

Only the enabled video inputs can be accessed by switching through the interface's video sources. It is recommended to enable only the required inputs. So the disabled inputs will be skipped while switching through the video interfaces inputs.

1.4.3. Rear-view camera setting (dip 5)

If set to **OFF**, the interface switches to factory picture while the reverse gear is engaged to display factory rear-view camera.

If set to **ON**, the interface switches to its rear-view camera input „V4 Reverse“ while the reverse gear is engaged.

1.4.4. Front camera activation type (Dip 6)

If the dip switch is set to **ON** (and dip1 is set to ON), the interface switches from the rear camera to the front camera input for 10 seconds after reverse gear is disengaged. In addition, manual switching to the front camera input is also possible from any image mode by pressing the button (short press).

With the dip switch set to **OFF** (and dip1 set to ON), automatic switch-back to the front camera is deactivated, but the manual front camera switching option via external keypad remains.

1.4.5. Video representation (dip7)

If dip7 is set to **ON** the inserted video is shown with big size.

If set to **OFF** the inserted video is shown with small size.



Note: Dips 4 and 8 are out of function and have to be set to **OFF**.

After each Dip-switch-change a power-reset of the Video Interface has to be performed!

1.5. Settings of the 4 Dip switches (CAN functions – red)

All 4 dip-switches of the video interface have no function for normal use and have to be set to OFF.

Dip position down is ON and position up is OFF.



Vehicle/Navigation	Dip 1	Dip 2	Dip 3	Dip 4
All vehicles	OFF	OFF	OFF	OFF

After each Dip-switch-change a power-reset of the Can-box has to be performed!

2. Installation

To install the interface, first switch off the ignition and disconnect the vehicle's battery. Please read the owner's manual of the car, regarding the battery's disconnection! If required, enable the car's Sleep-mode (hibernation mode) In case the sleep-mode does not succeed, the disconnection of the battery can be done with a resistor lead.

As with any installation of retrofit equipment, a stand-by test is necessary after the installation of the video interface, to ensure that the unit also switches off after reaching the vehicle's sleep mode.

Before the final installation, we recommend a test-run of the interface. Due to changes in the production of the vehicle manufacturer, there's always the possibility of incompatibility.

2.1. Place of connection

The interface has to be connected at the factory monitor.

2.2. Connection schema

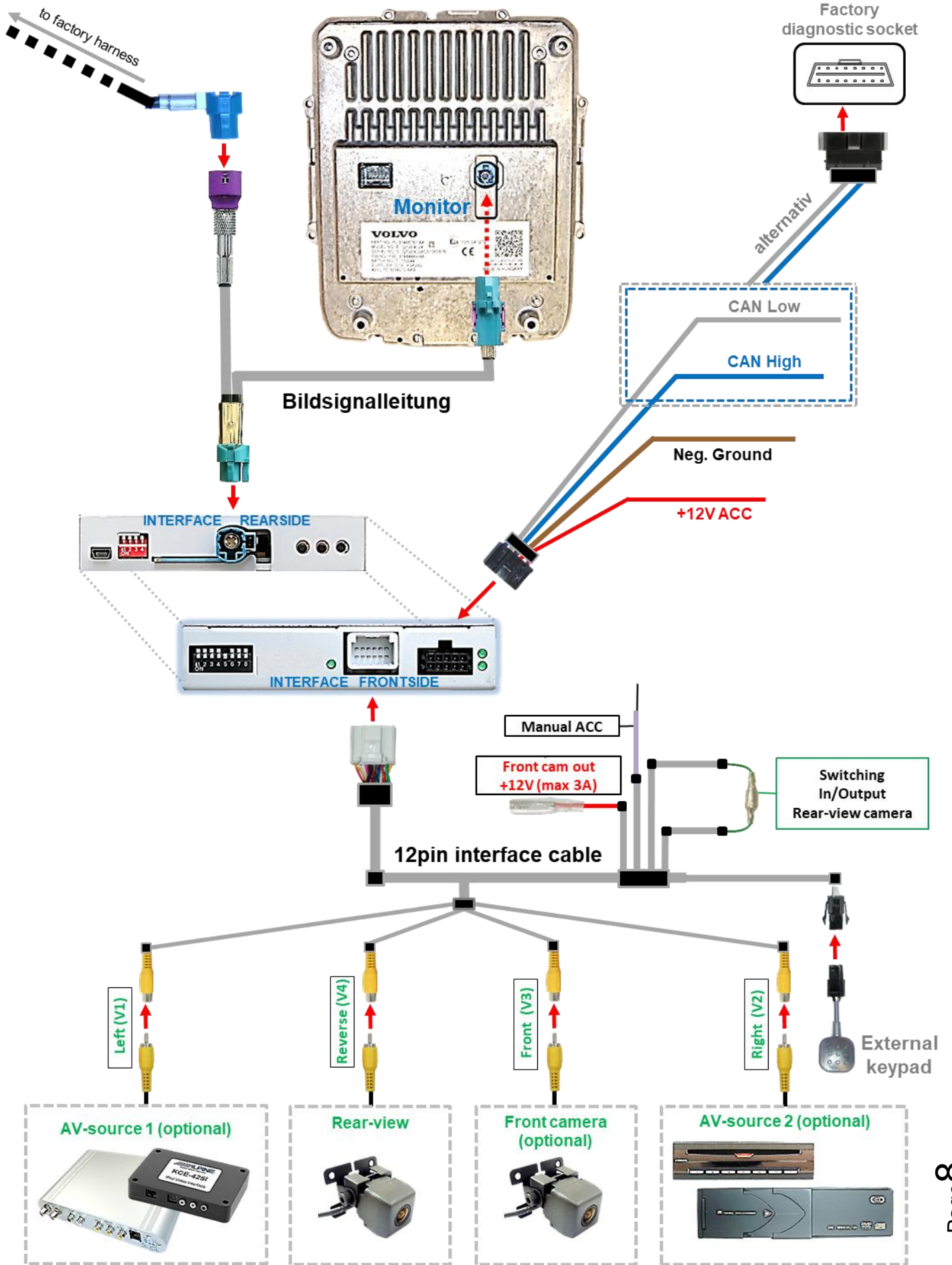

2.3. Connection – picture signal cable

Remove the head unit

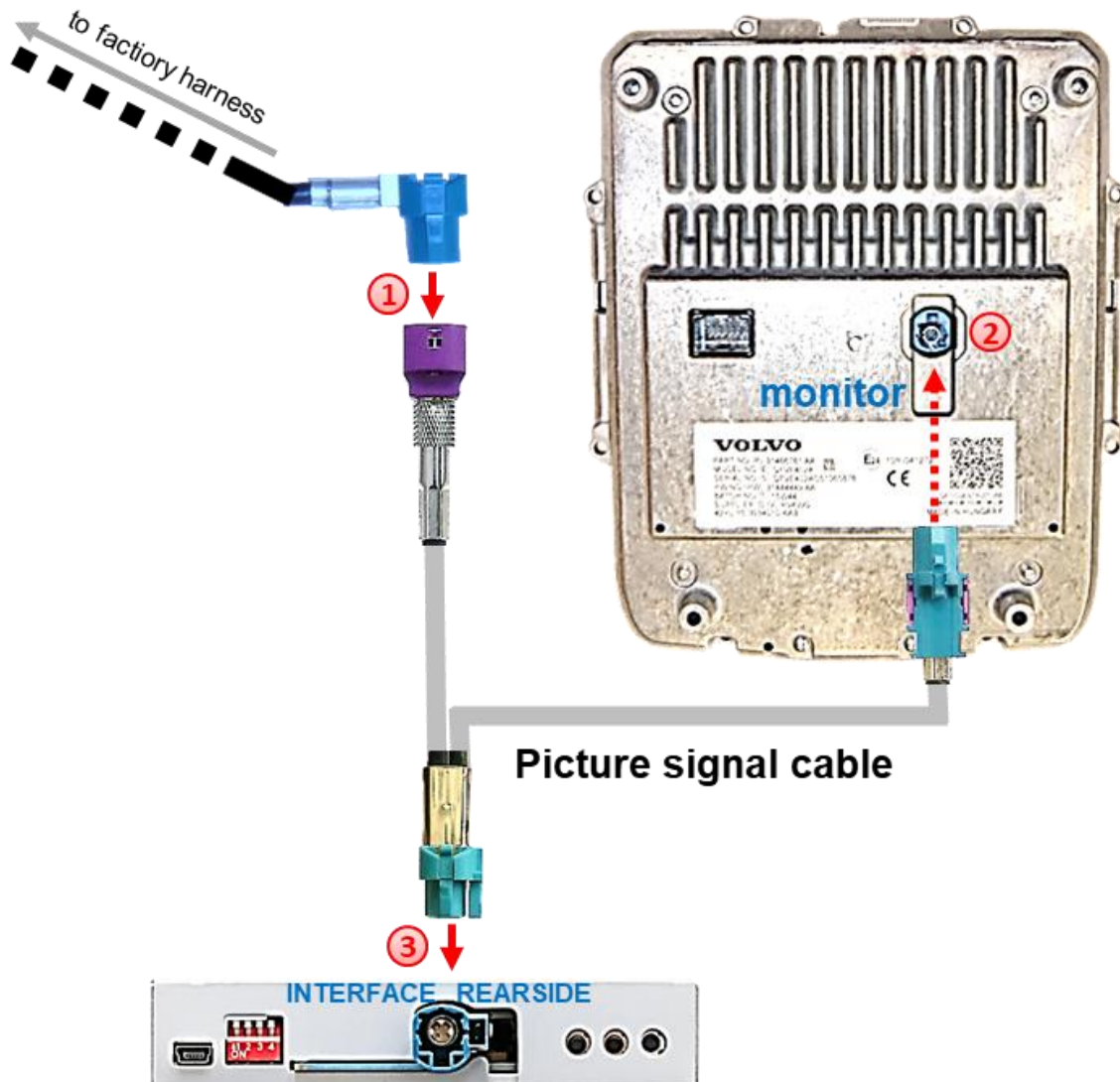

- ① Disconnect the factory picture signal cable's blue coloured female HSD connector from the monitor's rear-side and connect it to the purple coloured HSD connector of the enclosed picture signal cable.
- ② Connect the waterblue coloured female HSD connector of the enclosed picture signal cable to the monitor's previously become free blue coloured male HSD connector.
- ③ Connect the opposite female waterblue coloured HSD+2 connector of the picture signal cable to the waterblue coloured male HSD+2 connector of the video interface.

Note: The colours of the HSD connector of head unit and factory harness may vary.

2.4. Connection – 10pin Power / CAN cable

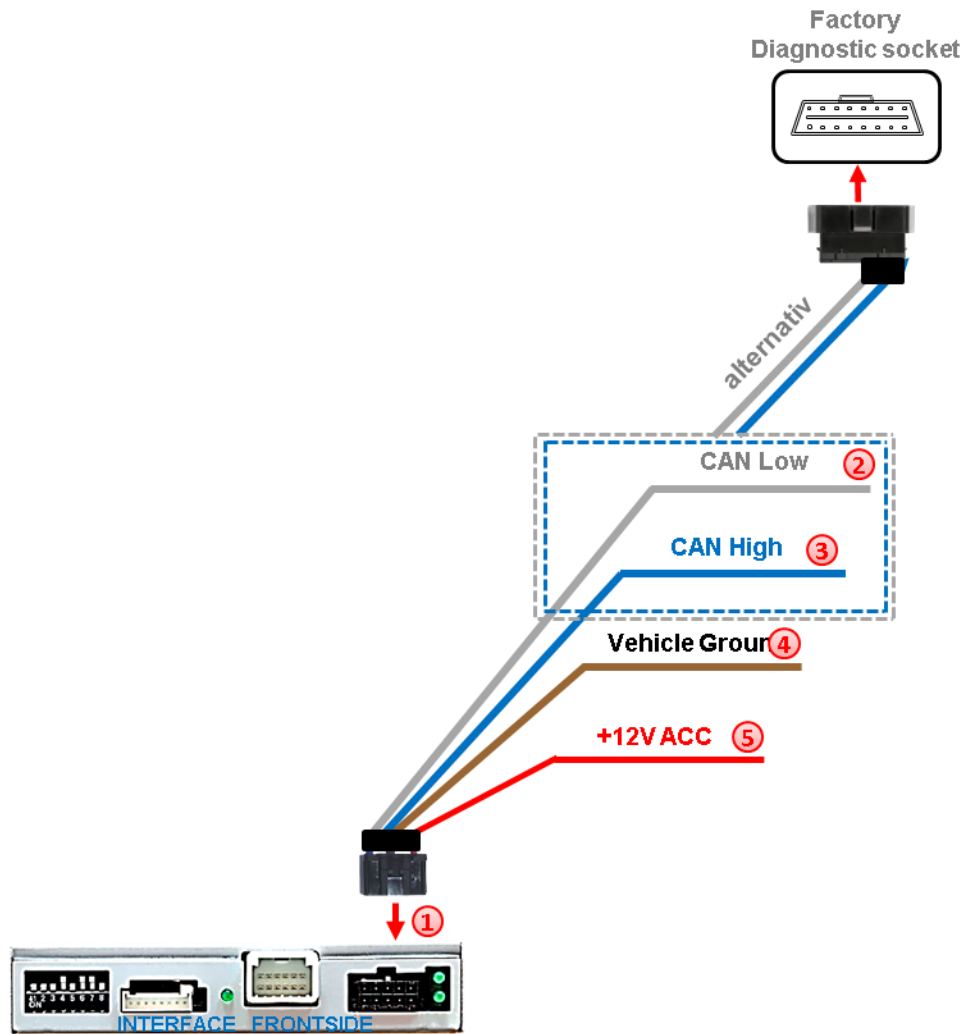

- 1 Connect the 10pin power / CAN cable's female 10pin connector to the 10pin connector of the video interface.
- 2 Connect the single **grey wire** of the 10pin power / CAN cable to the vehicle's CAN-Low.*
- 3 Connect the **blue wire** of the 10pin Power / CAN Cable to the vehicle's CAN-High.*

Note: To handle the CAN+ and the CAN- connection, the enclosed 20pin OBD connector can alternatively be used, but a perfect connection from behind without that connector will avoid loose problems and dysfunction.

*Experience values:

In the Volvo XC 40 and XC 60, the CAN wires are located in the left footwell in front of the A-pillar:

XC40

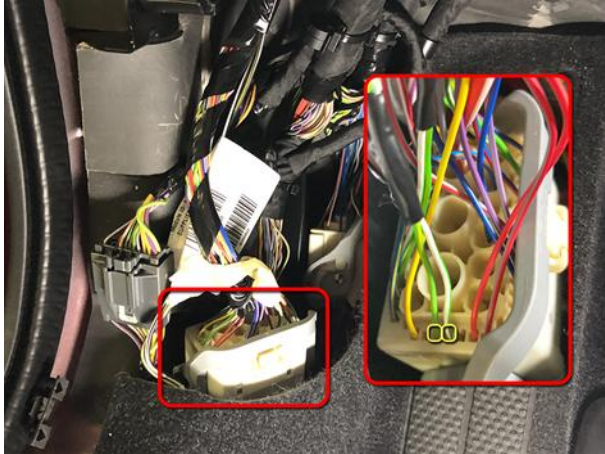

CAN High = white/green (pin 31)
CAN LOW = green/yellow (pin 32)

XC60



CAN High = white/green
CAN LOW = green/yellow

- 4 Connect the single **brown wire** of the 10pin Power / CAN Cable to vehicle's negative ground.
- 5 Connect the single **red wire** of the 10pin power/CAN cable to +12V ACC power supply.



Check 1

Exceptionally, the CAN communication may not succeed in all vehicles! If, after connecting the 10pin power cables, no interface LED lightens up while the ignition is turned on, the analog power supply needs to be done! (see following chapter)

Check 2

Exceptionally, the power supply to the video interfaces may not be interrupted after switching to the vehicle's sleep mode. If the interface LEDs continue to shine even in the vehicle's sleep mode, please contact the support!

2.5. Analogue power supply for the video interface

If the communication between the CAN box and the vehicle's CAN bus does not succeed (not all vehicles are compatible), the analogue connection is required.

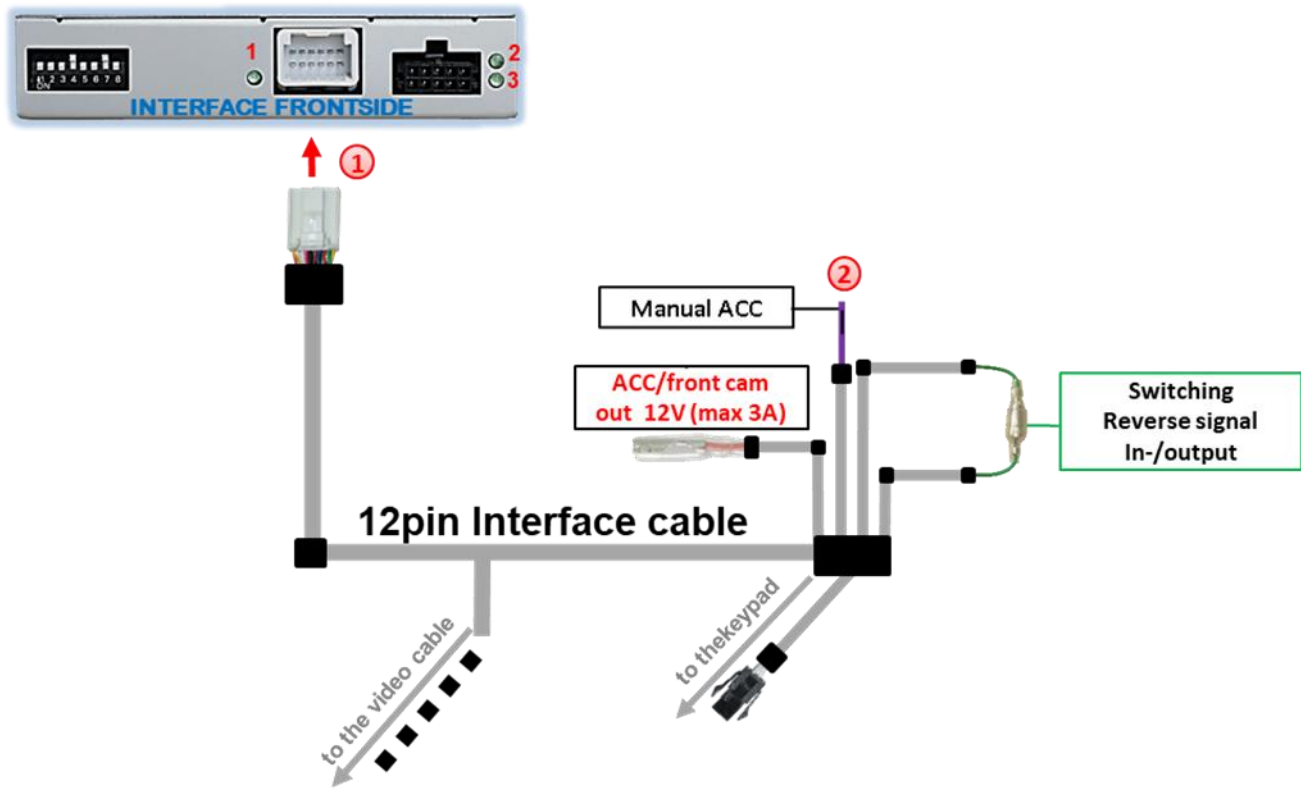

- 1 Connect the red wire **ACC-OUT** and the purple coloured wire **Manual ACC** of the 12pin interface cable to **+12V ACC power supply**.

2.6. Power supply output

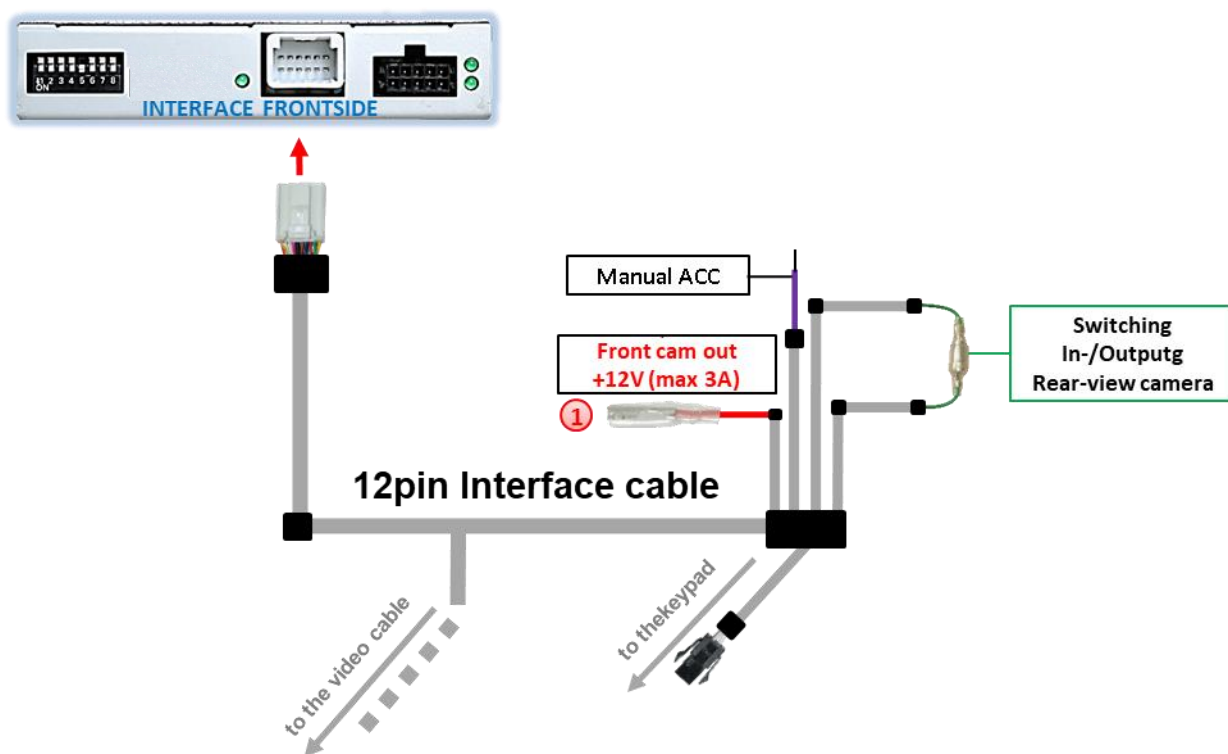

① The red power supply output **Front cam out +12V (max 3A)** can be used to power an external source and has a different assignment, depending on the position of dip switch 1 (of 8 dips):

Dip	Function
Dip 1 ON	+12V (max. 3A) when reverse gear is engaged plus 10 seconds delay after reverse gear is disengaged and +12V when manually switched to front camera by keypad (short press)
Dip 1 OFF	+12V permanent (max. 3A) ACC

2.7. Connection - video sources

It is possible to connect an after-market rear-view camera, an after-market front camera and two more video sources to the video-interface.

Before a final installation of the video sources, we recommend a test-run to ensure the compatibility of vehicle and interface. Due to changes in the production of the vehicle manufacturer there's always a possibility of incompatibility.

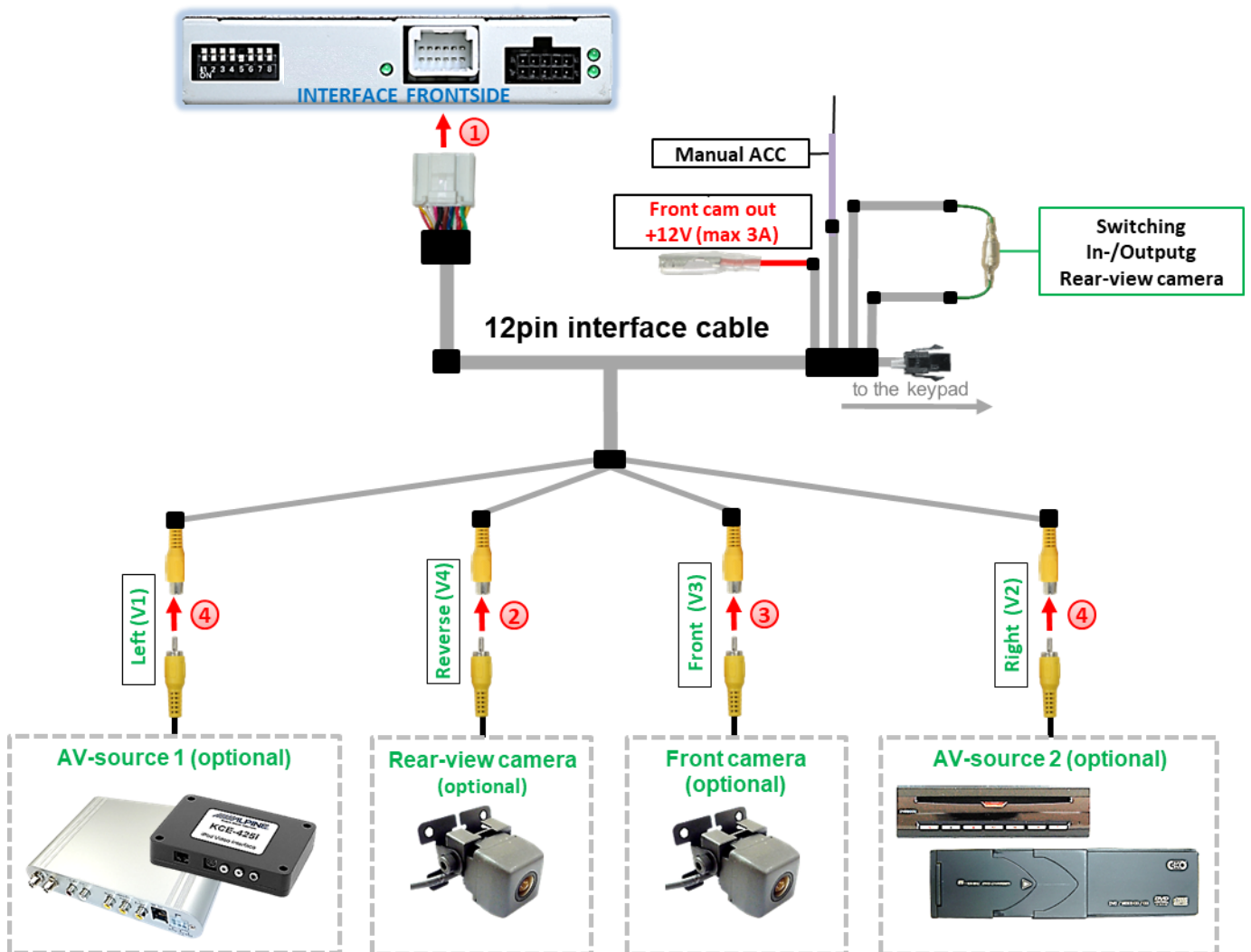

- 1 Connect the 12pin interface cable's female 12pin connector to the male 12pin connector of the video-interface.
- 2 Connect the video RCA of the Rear-view camera to the 12pin interface cable's female RCA connector „Reverse V4“.
- 3 Connect the front camera's video RCA connector to the 12pin interface cable's female RCA connector „Front V3“.
- 4 Connect the video RCA of the AV source 1 and 2 to the 12pin interface cable's female RCA connector “Left (V1)” and “Right (V2)”.

2.7.1. Audio-insertion

This interface is only able to insert video signals into the factory infotainment. If an AV-source is connected, the audio insertion has to be done by the factory audio AUX input or an FM-modulator. The inserted video-signal can be activated simultaneously to each audio-mode of the factory infotainment. If 2 AV sources shall be connected to the infotainment, additional electronic is necessary to switch the audio signals.

2.7.2. After-market front camera

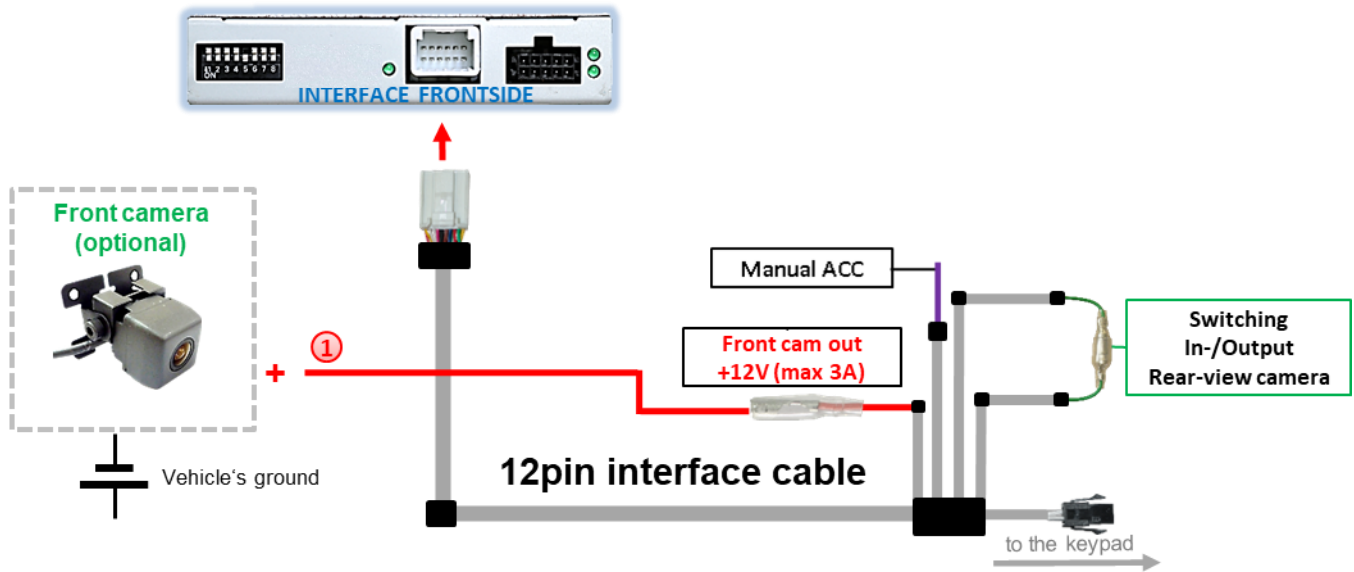

- ① The red power supply output **Front cam out +12V (max 3A)** can be used to power a front camera. If Dip 1 is set to ON (black 8 dips), the power supply output gives +12V (max 3A) when reverse gear is engaged

Note: In addition, a manual switch-over to the front camera input is possible via keypad (short press) from any image mode. The power supply output gives +12V then, as well (if Dip 1 is set to ON and the front camera input is selected).

Attention: A long press of the external keypad push button will switch the interface to the next source.

2.7.3. After-market rear-view camera

Some vehicles have a different reverse gear code on the CAN-bus which the video-interface is not compatible with. Therefore, there are two different ways of installation. If the video interface receives a signal of the reverse gear, the green wire **“Reverse-OUT”** of the 20pin cable should carry +12V while the reverse gear is engaged.

Note: Do not forget to set video interface’s dip5 to ON before testing.

2.7.3.1. Case 1: Interface receives the reverse gear signal

If the interface delivers +12V on the green output wire of the 12pin interface cable while reverse gear is engaged, the video interface will automatically switch to the rear-view camera input **“Camera IN”** while the reverse gear is engaged.

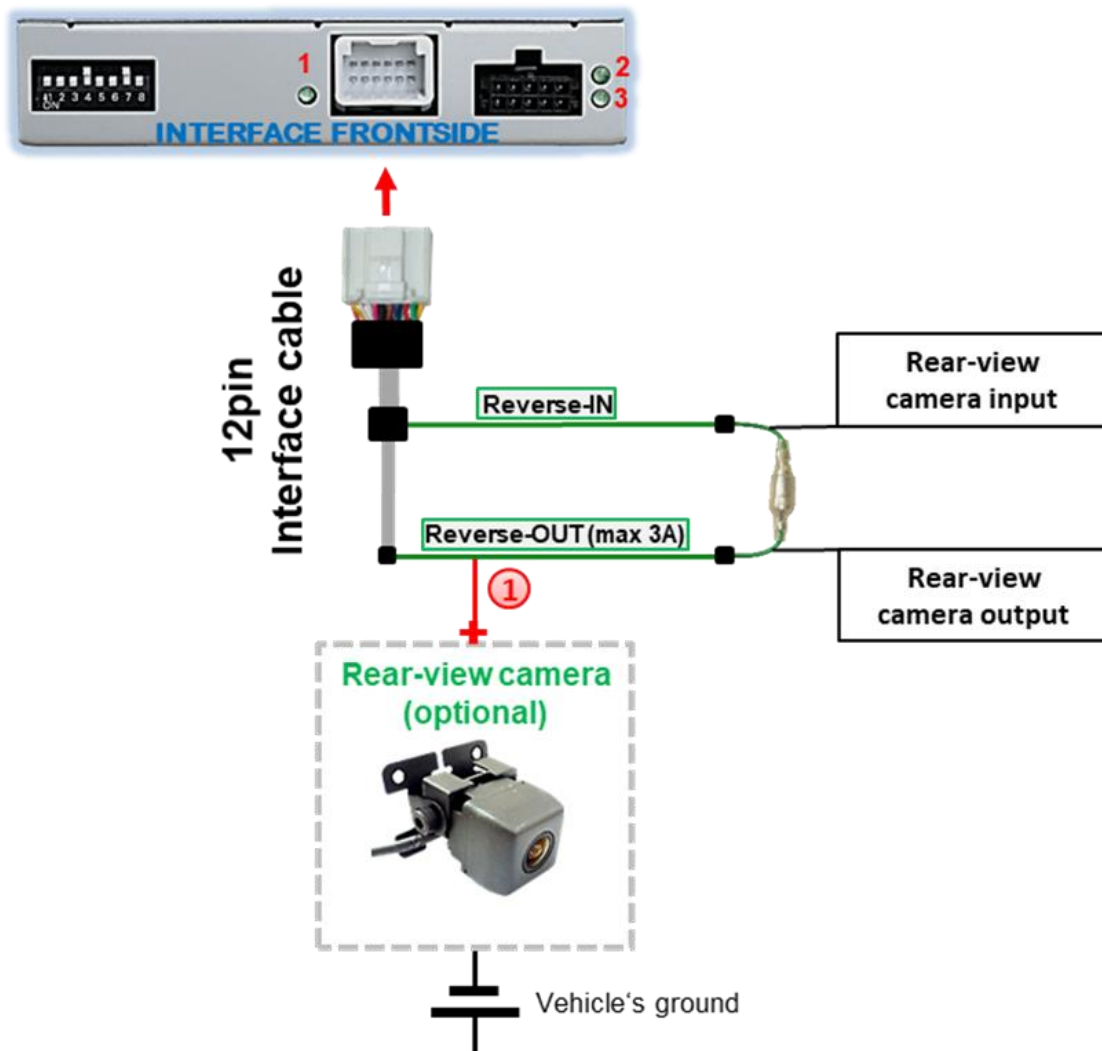

- 1 The 12 V power supply for the rear-view camera (max 3A) has to be taken from the 12pin interface cable’s green wire **“Reverse-OUT”** to avoid an unnecessary, permanent power supply to the camera electronic. Both green cables **“Reverse IN”** and **“Reverse OUT”** have to remain connected.

2.7.3.2. Case 2: Interface does not receive the reverse gear signal

If the video interface does not deliver +12V on the green wire of the 12pin cable when reverse gear is engaged (not all vehicles are compatible), an external switching signal from the reverse gear light is required. As the reverse gear light's power supply isn't voltage-stable all the time, an ordinary open relay (e.g. AC-RW-1230 with wiring AC-RS5) or filter (e.g. AC-PNF-RVC) is required. The diagram below shows the connection type of the relay.

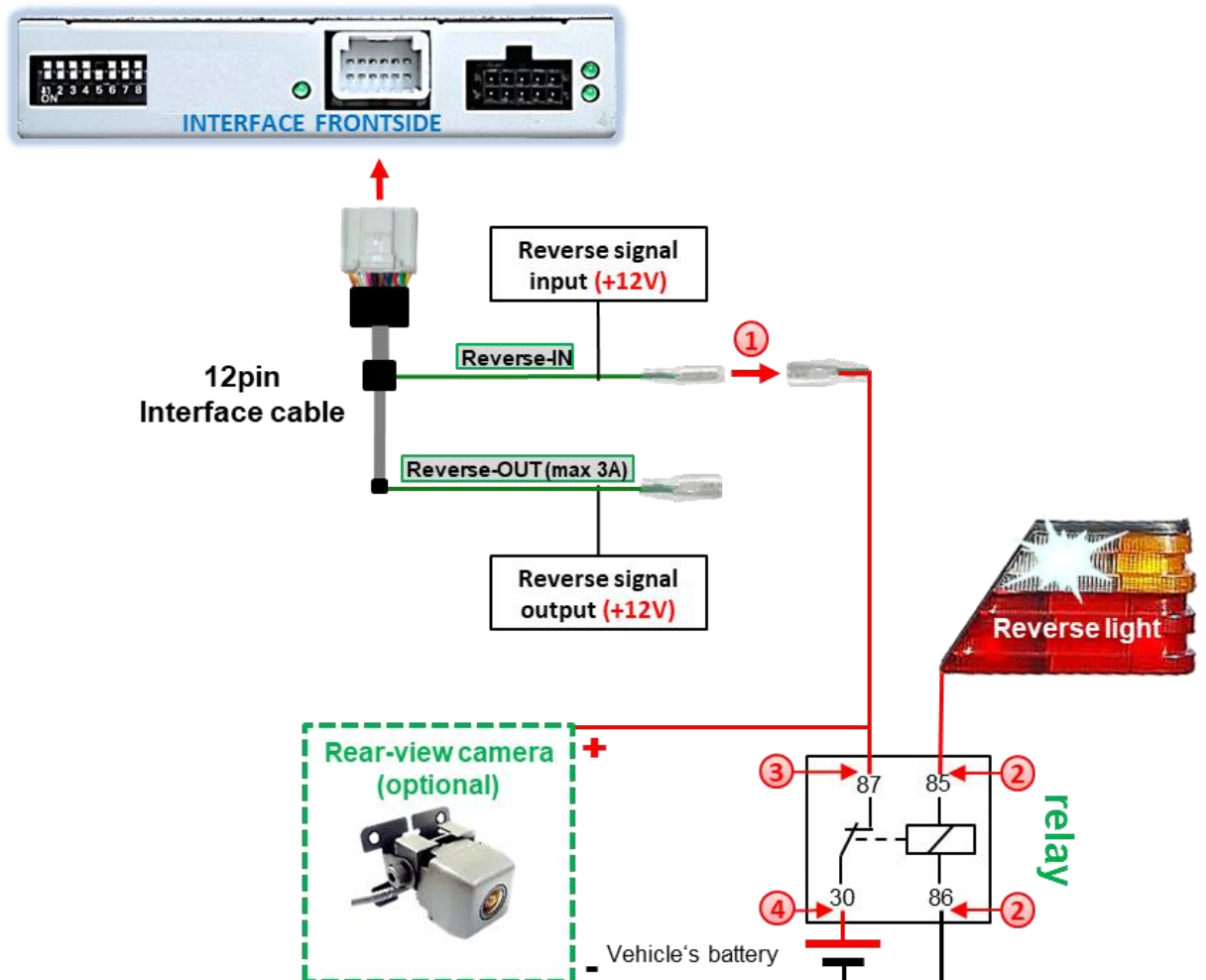

- 1 Disconnect the green cable's preconnected male- and female connectors of the 12pin interface cable and connect the green input cable "Reverse-IN" to the output connector (87) of the relay.

Note: Last but not least to avoid short circuits, the best solution should be, to crimp a male 4mm connector to the relay's output cable and connect it to the green cable's female 4mm connector. The output-cable "Reverse-OUT" remains disconnected as it's out of function.

- 2 Connect the Reverse light's power-cable to coil (85) and the vehicle's ground to coil (86) of the relay.
- 3 Connect the output connector (87) of the relay to the rear-view camera's power-cable, like you did it to the green "Reverse-IN" cable before.
- 4 Connect stable and permanent +12V to the relay's input connector (30).

2.8. Connection - video-interface and external keypad

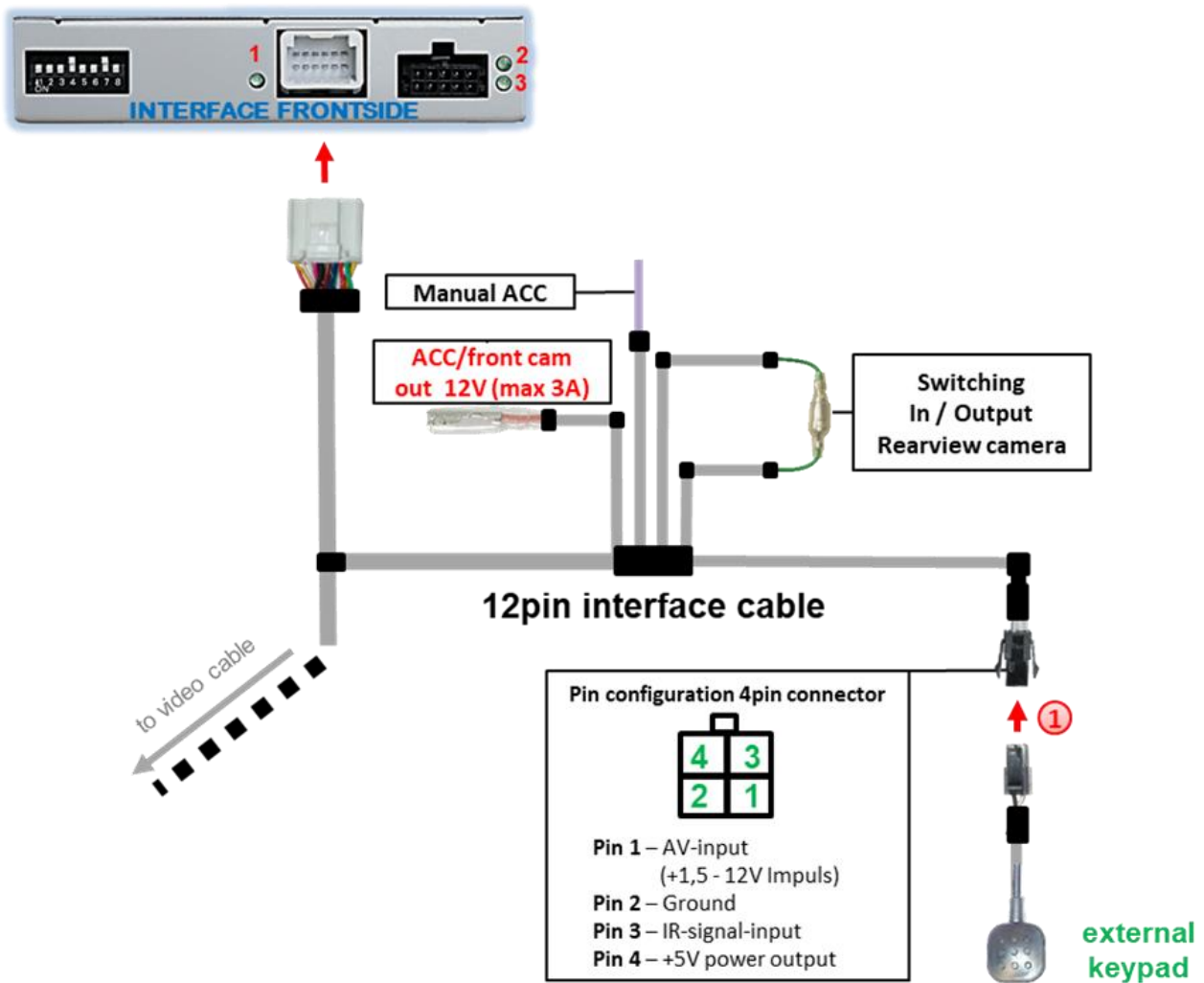

- ① Connect the female 4pin connector of the keypad to the male 4pin connector of the 12pin interface cable.

Note: Even if switching through several video sources by the keypad mightn't be required, the invisible connection and availability is strongly recommended.

2.9. Picture settings

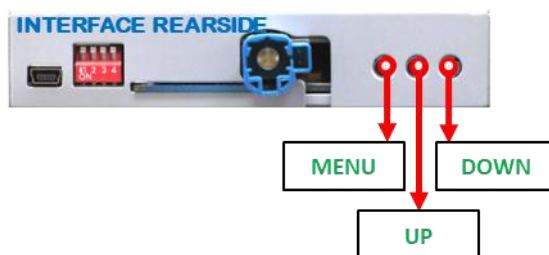

The picture settings are adjustable by the 3 push-buttons at the rear-side of the video-interface. Press the MENU button to open the OSD settings menu or to switch to the next menu item. Press UP and DOWN to change the selected value. The buttons are placed inside in the housing to avoid accidental changes during or after the installation. Picture settings must be done separately for all video inputs while the corresponding input is selected and visible on the monitor.

Note: The OSD menu is only shown when a working video source is connected to the selected video-input of the interface.

Contrast
Brightness
Saturation
Position H = horizontal picture position)
Position V = vertical picture position)
Guide-Pos = no function
H-SIZE = horizontal picture size
V-SIZE = vertical picture size

Contrast	50
Brightness	50
Saturation	24
Position-H	7
Position-V	20
Guide-Pos	0
H-Size	16
V-Size	16

3. Interface operation

3.1. By factory infotainment button

Press „HOME“ key
for 3 seconds

(to switch video sources)



To switch the interface's activated video sources, the factory infotainment buttons can be used.

Press the according infotainment button to switch the input from the factory video to the inserted video sources. If all inputs are activated by dip switch settings, the order is the following:

Factory video → Video IN 1 → Video IN 2 → factory video

Each press will switch to the next enabled input. Inputs which are not enabled will be skipped.

Switchover by vehicle buttons isn't possible in all vehicles. In some vehicles the external keypad has to be used.

3.2. By keypad

Alternatively or additionally to the factory infotainment buttons, the interface's external keypad can be used to switch the enabled inputs. Even if not needed, the keypad should always remain connected to the video interface for support purposes.

➤ Long press of keypad (2-3 seconds)

By long pressing the external keypad (2-3 seconds), the video interfaces switches the input from the factory video to the inserted video sources. Each long press will switch to the next enabled input. Inputs which are not enabled will be skipped.

Note: The interface switches after releasing the switch (after long pressure).

➤ Short press of keypad (only if DIP 1 is set to ON)

By short pressing the external keypad, the video interfaces switches from the factory video to the front camera input and back to factory video.

4. Specifications

BATT/ACC range	7V - 25V
Stand-by power drain	5mA
Power	250mA @12V
Video input	0.7V - 1V
Video input formats	NTSC
Temperature range	-40°C to +85°C
Dimensions video-box	118 x 25 x 104 mm (W x H x D)

5. FAQ – Trouble shooting Interface functions

For any troubles which may occur, check the following table for a solution before requesting support from your vendor.

Symptom	Reason	Possible solution
No picture/black picture (factory picture).	Not all connectors have been reconnected to factory head-unit or monitor after installation.	Connect missing connectors.
	No power on CAN-bus box (all LED CAN-bus box are off).	Check power supply of CAN-bus box. Check CAN-bus connection of CAN-bus box.
	CAN-bus box connected to CAN-bus in wrong place.	Refer to the manual where to connected to the CAN-bus. If not mentioned, try another place to connect to the CAN-bus.
	No power on video-interface (all LED video-interface are off).	Check whether CAN-bus box delivers +12V ACC on red wire output of 8pin to 6pin cable. If not cut wire and supply ACC +12V directly to video-interface.
No picture/black picture/white picture (inserted picture) but factory picture is OK.	No picture from video source.	Check on other monitor whether video source is OK.
	No video-source connected to the selected interface input.	Check settings dips 1 to 3 of video interface which inputs are activated and switch to corresponding input(s).
	LVDS cables plugged in wrong place.	Double-check whether order of LVDS cables is exactly connected according to manual. Plugging into head-unit does not work when the manual says to plug into monitor and vice versa.
Inserted picture totally wrong size or position.	Wrong monitor settings of video-interface.	Try different combinations of dips 7 and 8 of video-interface. Unplug 6pin power after each change.
Inserted picture double or 4 times on monitor.		
Inserted picture distorted, flickering or running vertically.	Video sources output set to AUTO or MULTI which causes a conflict with the interfaces auto detection.	Set video source output fixed to PAL or NTSC. It is best to set all video sources to the same standard.
	If error occurs only after source switching: Connected sources are not set to the same TV standard.	Set all video sources to the same standard.
	Some interfaces can only handle NTSC input.	Check manual whether there is a limitation to NTSC mentioned. If yes, set source fixed to NTSC output.
Inserted picture b/w.	Picture settings have not been adjusted.	Use the 3 buttons and the interface's OSD to adjust the picture settings for the corresponding video input.
Inserted picture qual. bad.		
Inserted picture size slightly wrong.		
Inserted picture position wrong.		
Camera input picture flickers.	Camera is being tested under fluorescent light which shines directly into the camera.	Test camera under natural light outside the garage.
Camera input picture is bluish.	Protection sticker not removed from camera lens.	Remove protection sticker from lens.

Symptom	Reason	Possible solution
Camera input picture black.	Camera power taken directly from reverse gear lamp.	Use relay or electronics to "clean" reverse gear lamp power. Alternatively, if CAN-bus box is compatible with the vehicle, camera power can be taken from green wire of 6pin to 8pin cable.
Camera input picture has distortion.		
Camera input picture settings cannot be adjusted.	Camera input picture settings can only be adjusted in AV2 mode.	Set dip 3 of video-interface to ON (if not input AV2 is not already activated) and connect the camera to AV2. Switch to AV2 and adjust settings. Reconnect camera to camera input and deactivate AV2 if not used for other source.
Graphics of a car in camera input picture.	Function PDC is ON in the interface OSD.	In compatible vehicles, the graphics will display the factory PDC distance. If not working or not wanted, set interface OSD menu item UI-CNTRL to ALLOFF.
Chinese signs in camera input picture	Function RET or ALL is ON (function for Asian market) in the interface OSD.	Set interface OSD menu item UI-CNTRL to ALLOFF or PDCON.
Not possible to switch video sources by OEM button.	CAN-bus interface does not support this function for vehicle.	Use external keypad or cut white wire of 6pin to 8pin cable and apply +12V impulses for AV-switching.
Not possible to switch video sources by external keypad.	Pressed too short.	For video source switching a longer press of about 2.5 seconds is required.
	SW-version of interface does not support external keypad.	Use OEM-button or cut white wire of 6pin to 8pin cable and apply +12V impulses for AV-switching.
Interface does not switch to camera input when reverse gear is engaged.	CAN-bus interface does not support this function for the vehicles.	Cut the green wire of the 6pin to 8pin cable and apply +12V constant from reverse gear-lamp signal. Use relay to "clean" R-gear lamp power.
Interface switches video-sources by itself.	CAN-bus interface compatibility to vehicle is limited.	Cut the grey wire of 6pin to 8pin and isolate both ends. If problem still occurs, additionally cut the white wire of 6pin to 8pin cable and isolate both ends.



Made in China