

Video inserter CI-HDV-CR2 / CI-HDA-CR2

Compatible with
Citroen, Fiat and Opel vehicles
with all-in-one head unit CRONY2 with 10.25inch monitor



Example

Attention!
The video signal type of each video source must be defined in the OSD menu of the corresponding video input.

Product features

- 1 x CVBS/AHD input for rear-view camera
- 1 x CVBS/AHD input for front camera
- 2 x CVBS/AHD input for side cameras or additional after-market video-sources (e.g. USB devices, DVB-T2 tuner, etc.)
- All inputs NTSC and PAL compatible
Supported AHD resolutions 720p NTSC (30Hz), 720p PAL (25Hz), 960p NTSC (30Hz), 960p PAL (25Hz), 1080p NTSC (30Hz), 1080p PAL (25Hz)
- **HDV-CR2 only:** 1 HDMI input for HD rear-view camera or other HDMI source (e.g. iOS/Android device, laptop, streaming stick, DVB-T2 tuner, etc.)
Supported HDMI resolutions (720p NTSC (60Hz), 720p PAL (50Hz), 1080p NTSC (60Hz), 1080p PAL (50Hz))
- **HDV-CR2 only:** Analogue audio output for the HDMI source
- Automatic switchover to rear-view camera input while reverse gear is engaged
- Automatic front camera switching while reverse gear is engaged for 5, 10, 15 or 20 second intervals
- Adjustable guide lines (fixed or movable) for rear-view camera can be activated (movable guide lines not available for all vehicles)
- Picture free while driving (ONLY for fed-in video sources)

Table of contents

1	Before installation	3
1.1	Scope of delivery	3
1.2	Checking interface compatibility with vehicle and accessories	4
1.3	Boxes and connections	5
1.3.1	Connections – video interface	5
1.3.2	Connections – daughter PCB	6
1.4	Settings – 8 dip switch bench (interface functions)	7
1.4.1	Interface video inputs "V1-Left" and "V2 Right" (Dip 1-2)	7
1.4.2	Front camera input "V3 front" (Dip 3)	7
1.4.3	Rear-view camera settings (Dip 4)	8
1.4.4	Connection type of the rear-view camera (Dip 5)	8
1.4.5	HDMI input (Dip 6)	8
1.5	Settings – 4 dip switch bench (CAN bus)	9
2	Installation	9
2.1	Place of connection	9
2.2	Connection schema	10
2.3	Installation – daughter PCB	12
2.4	Connection – picture signal cable	17
2.5	Connection – Cable sets, power supply and CAN bus or analogue without CAN bus	18
2.5.1	Connection with CAN bus	19
2.5.2	Analogue connection without CAN bus	20
2.6	Power supply outputs	21
2.6.1	Connection and power supply - Video sources Rear-view camera, front camera and 2 side cameras	22
2.6.2	Connection and power supply – video sources rear-view camera, front camera and 2 video sources	23
2.7	Aftermarket rear-view camera	24
2.7.1	Case 1: Reverse gear signal from CAN bus	24
2.7.2	Case 2: Reverse gear signal from analogue signal	25
2.8	Aftermarket front camera	26
2.9	Aftermarket side cameras	27
2.9.1	Case 1: Turn signals from CAN bus	27
2.9.2	Case 2: turn signals from analogue signal	28
2.10	HDMI rear-view camera or other HDMI sources (HDV-CR2 only)	29
2.11	Audio insertion	30
2.12	Connection – video interface and external keypad	30
2.13	settings OSD menu	31
3	Operating the video interface	35
3.1	Optional: Operating the video interface via the "HDA-RC" remote control	35
4	Specifications	36
5	FAQ - Troubleshooting interface functions - product-specific	36
6	FAQ - Troubleshooting Interface functions - general	37

Legal notice

The driver must not be distracted, either directly or indirectly, by moving pictures while driving. In most countries/states, this is prohibited by law. We therefore accept no liability for property damage or personal injury caused directly or indirectly by the installation and operation of this product. In addition to operation when stationary, this product is only intended for displaying static menus (e.g. MP3 menu from USB devices) or pictures from (rear-view) cameras while driving.

Changes/updates to the vehicle software may impair the functionality of the interface. Software updates for our interfaces are provided to customers free of charge for up to one year after purchase of the interface. The interface must be sent in free of charge for the update. Costs for installation and removal will not be reimbursed.

1 Before installation

These instructions must be read before installation. Specialist knowledge is required for installation. The interface must not be installed near sources of moisture or heat.

Before final installation in the vehicle, we recommend a test run after connection to ensure that the vehicle and interface are compatible. Due to production-related changes by the vehicle manufacturer, there is always the possibility of incompatibility.

1.1 Scope of delivery

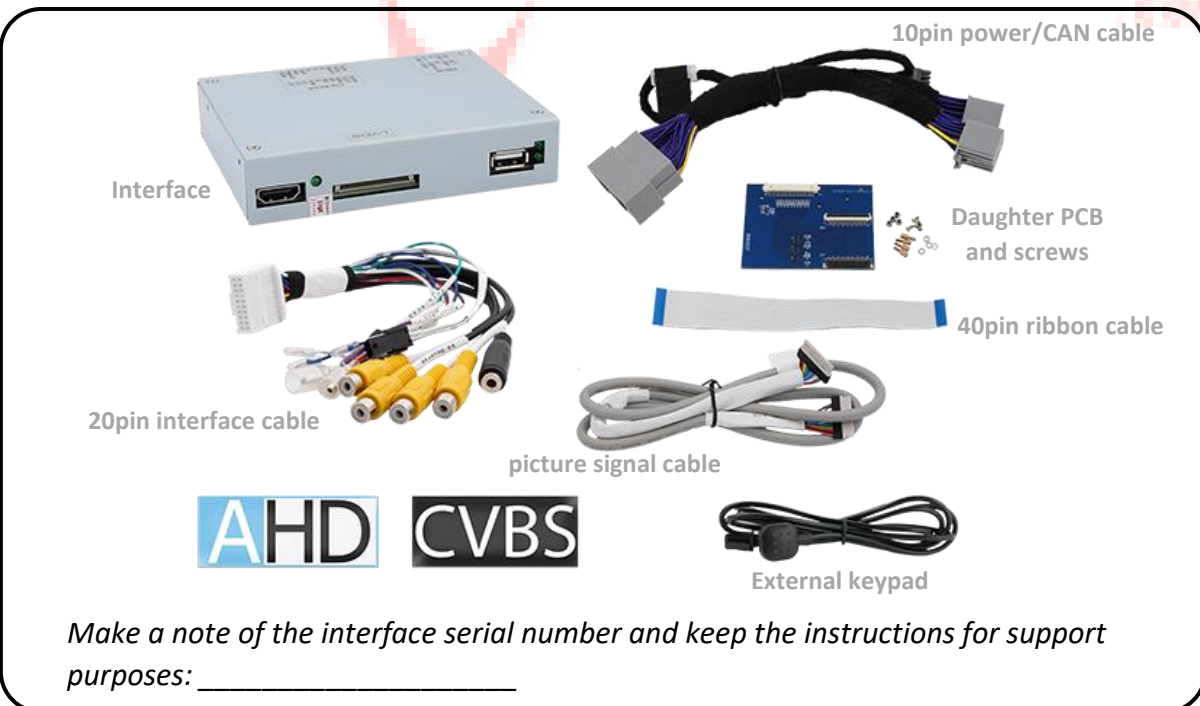

1.2 Checking interface compatibility with vehicle and accessories

Requirements

Manufacturer	Compatible vehicles	Compatible systems
Citroen	C3 4thGen from 04/2024, C3 Aircross 3rdGen from 06/2024	Clarion's CRONY2 with a 10.25inch monitor and all-in-one head unit
Fiat	Grande Panda from 03/2025	Clarion's CRONY2 with a 10.25inch monitor and all-in-one head unit
Opel	Frontera from 07/2024	Clarion's CRONY2 with a 10.25inch monitor and all-in-one head unit

Limitations

CAN bus compatibility

CAN-bus compatibility of interface may to some vehicles have no or limited compatibility. This can show on installation as well as later. Interface and all its video-inputs can be operated with analogue trigger signals, without connection to vehicle CAN-bus. In this case, individual additional functions are not available, see chapter 2.5.2 *Analogue connection without CAN bus* .

Video only

The interface does not insert **any** audio signals. To insert audio signals, any factory audio AUX input or optional products must be used (e.g. FM modulator). For an inserted HDMI source, audio is output via an analogue audio output (3.5 mm jack socket).

Input video image

To ensure better image quality, the input video image is displayed on the monitor in a reduced size, i.e. it does not cover the entire monitor size.

Factory rear-view camera

Automatic switching to rear-view camera input only occurs while reverse gear is engaged. Optional accessories are required for different switching times.

Aftermarket front camera

Switching to the front camera occurs automatically after reverse gear has been engaged for 5, 10, 15 or 20 seconds (depending on the OSD menu setting). Manual switching to the front camera is also possible via the external keypad.

Guide lines

If the vehicle CAN bus is not fully compatible with the interface or if an analogue connection is used, the movable guide lines for the rear-view camera cannot be used.

1.3 Boxes and connections

1.3.1 Connections – video interface

The video interface converts video signals from after-market sources into a video signal compatible with the factory head unit. This is inserted into the factory monitor via various switching options. It also reads digital signals from the vehicle CAN bus and converts them for its own functions.

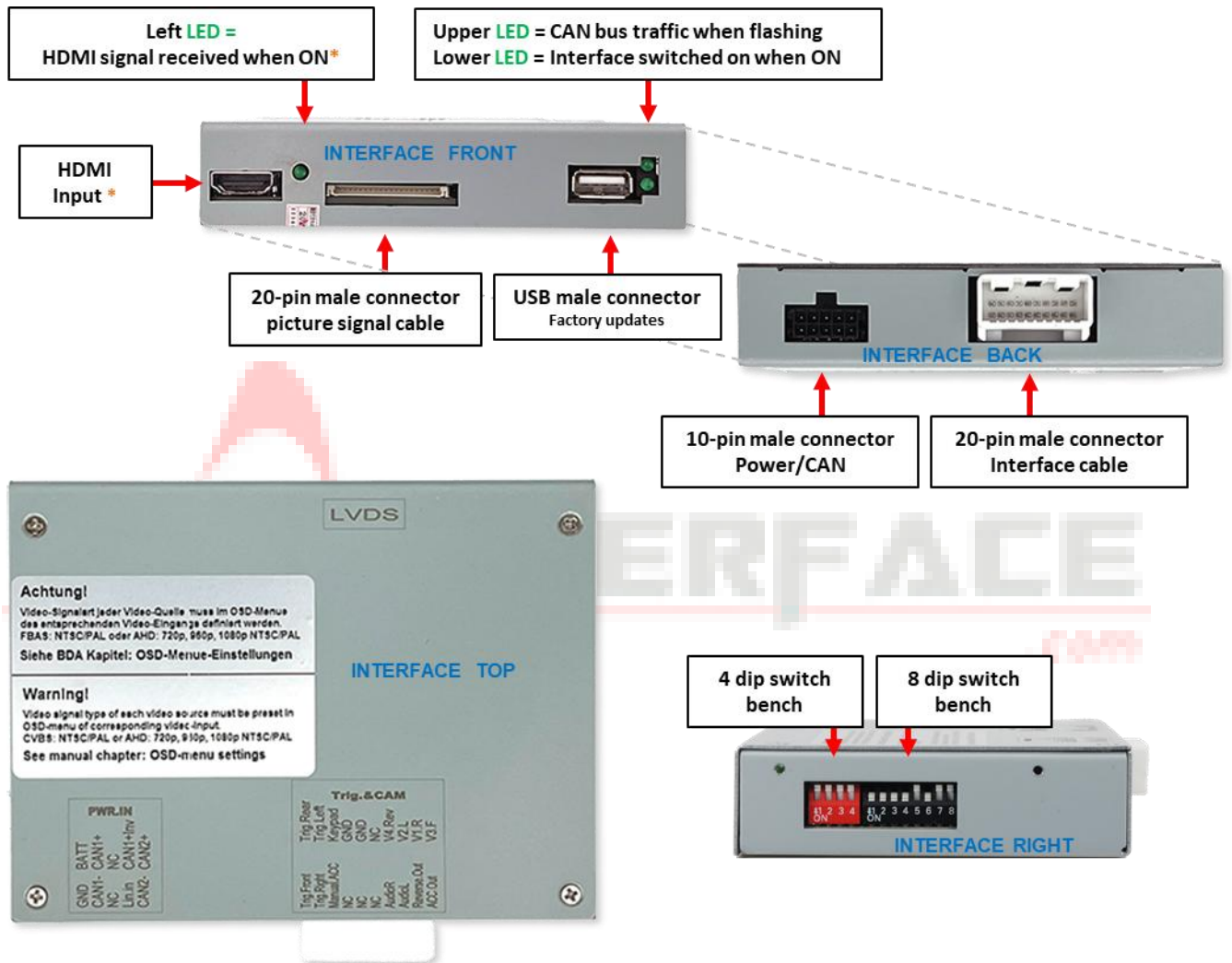

* HDMI input only available with HDV-CR2

1.3.2 Connections – daughter PCB

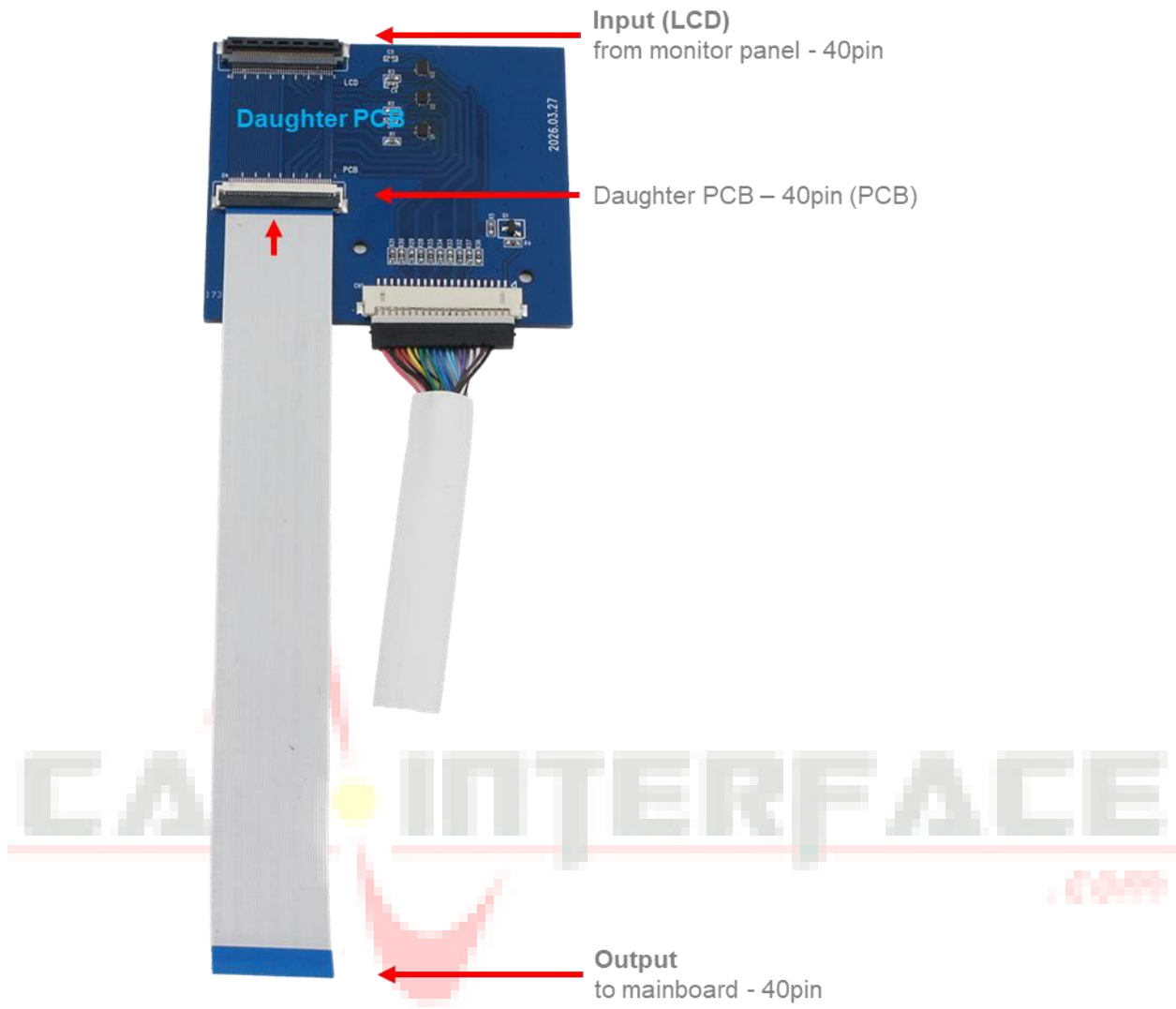

1.4 Settings – 8 dip switch bench (interface functions)

Interface box, right side, black



Dip position **UP = OFF (up)** and **DOWN = ON (down)**

Dip	Function	ON (down)	OFF (up)
1	Video 1 / V1-Left	activated	deactivated
2	Video 2 / V2-Right	activated	deactivated
3	Front camera / V3-Front	activated*	deactivated
4	Type of rear-view camera (V4 Reverse)	Aftermarket	Factory or none
5	Connection type of the Aftermarket rear-view camera*	HDMI*	V4 Reverse (CVBS/AHD)
6	HDMI input*	Enabled	deactivated
7	No function	-	set to OFF
8	No function	-	set to OFF

Power reset interface after each dip change to activate changes!

* Switching to the front camera occurs automatically for 5, 10, 15 or 20 seconds (depending on the OSD menu setting) after reverse gear is engaged.

* Dip 5 and Dip 6 have no function with **HDA-CR2**. Set to **OFF**.

** The factory PDC display must also be activated via Dip 7. **This does not set the position of the PDC display, but tells the interface where to find the factory PDC graphic.** After activation, the PDC display is always located to the right of the picture from an aftermarket rear-view camera.

See following chapters for detailed information about 8dip switch bench.

1.4.1 Interface video inputs "V1-Left" and "V2 Right" (Dip 1-2)

With Dip 1 (Dip 2) = **ON**, the CVBS/AHD input **V1-Left (V2 Right)** is activated for the side camera or other video sources. Only activated video inputs can be accessed – both with automatic and manual switching. It is recommended to only activate inputs that are in use, to avoid accidental switching.

1.4.2 Front camera input "V3 front" (Dip 3)

When Dip 3 = **ON**, the interface switches to the CVBS/AHD front camera input **V3-Front** after reverse gear is engaged. In addition, manual switching to the front camera input is possible from any picture mode via an external keypad (short press).

In the OSD menu settings, the automatic display time of the front camera can be selected between 5, 10, 15 or 20 seconds or switched off. Then another video source could also be connected to instead of a front camera.

1.4.3 Rear-view camera settings (Dip 4)

When Dip 4 = **OFF**, the interface switches to the factory image for the existing factory rear-view camera or factory PDC display as long as reverse gear is engaged.

With Dip 4 = **ON**, the interface switches to its CVBS/AHD rear-view camera input **V4-Reverse** (provided Dip 5 is set to OFF) or the **HDMI input*** (provided Dip 5 and Dip 6 are set to **ON**) when reverse gear is engaged.

Note: **V4-Reverse** remains inactive when Dip 5 = ON and an HDMI camera is used, resulting in no function.

1.4.4 Connection type of the rear-view camera (Dip 5)

With Dip 5 = **ON**, the **HDMI input*** is selected as the rear-view camera input. In addition, the **HDMI input*** must be activated with Dip 6 = **ON**.

With Dip 5 = **OFF**, the **V4 -Reverse** input is selected as the rear-view camera input.

Note: Automatic switching to the front camera for the preset time occurs in both cases after reverse gear is engaged.

1.4.5 HDMI input (Dip 6)

With Dip 6 = **ON**, the **HDMI input*** is activated and can be used for various HDMI sources (e.g. rear-view camera or 360° camera system, smartphone, laptop, streaming stick, DVB-T2 tuner, etc.) . For rear-view camera/360° camera system, Dip 5 must also be set to **ON**.

With Dip 6 = **OFF**, the HDMI input* is deactivated.

Note: Dips 7 and 8 have no function and must be set to OFF.

Power reset interface after each dip change to activate changes!

*** HDMI input only available with HDV-CR2**

1.5 Settings – 4 dip switch bench (CAN bus)

Interface box, right side, red

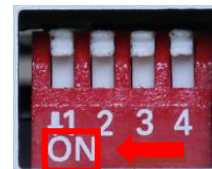

Set the DIP switch positions according to the following table.

Dip position UP = OFF (up) and DOWN = ON (down)

Dip	Function	ON (down)	OFF (up)
1	No function	-	Set to OFF
2	No function	-	Set to OFF
3	No function	-	Set to OFF
4	No function	-	Set to OFF

Power reset interface after each dip change to activate changes!

2 Installation

Switch off the ignition and disconnect the vehicle battery in accordance with the manufacturer's instructions!

If the vehicle battery must not be disconnected according to the manufacturer's specifications, it is usually sufficient to put the vehicle into sleep mode. If this does not work, disconnect the vehicle battery with a resistor cable.

Before final installation, we recommend a test run of the interface with all connected devices to ensure that all parts are compatible. Due to possible changes in the vehicle manufacturer's production at any time, incompatibility can never be ruled out.

As with any installation of retrofit devices, a quiescent current test of all retrofitted devices must be carried out after installation to ensure that the devices switch to standby mode when the vehicle is in sleep mode.

2.1 Place of connection

The daughter PCB is installed inside the head unit. The video interface is connected to the daughter PCB and to the rear of the head unit.

2.2 Connection schema

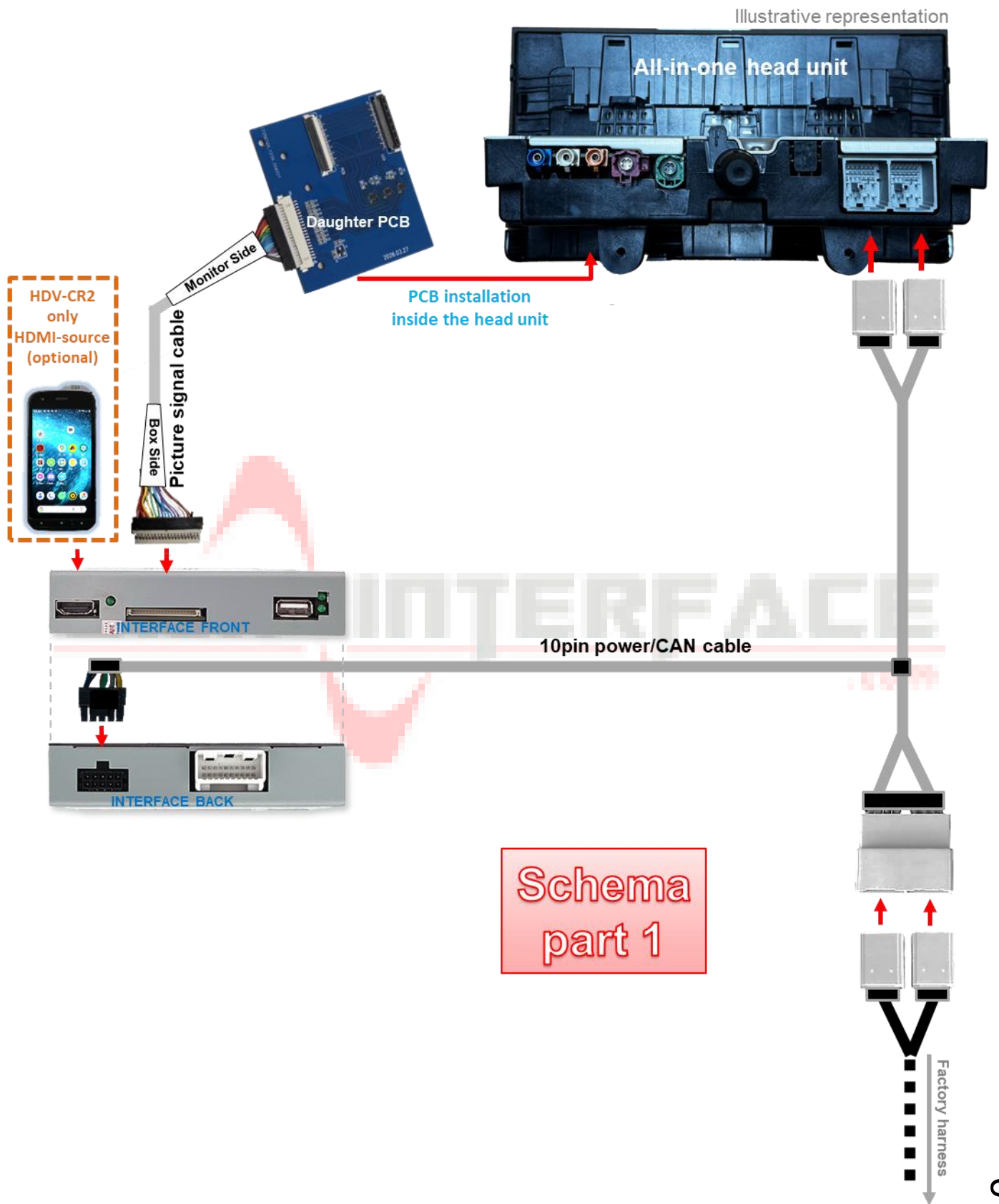

Schema part 2

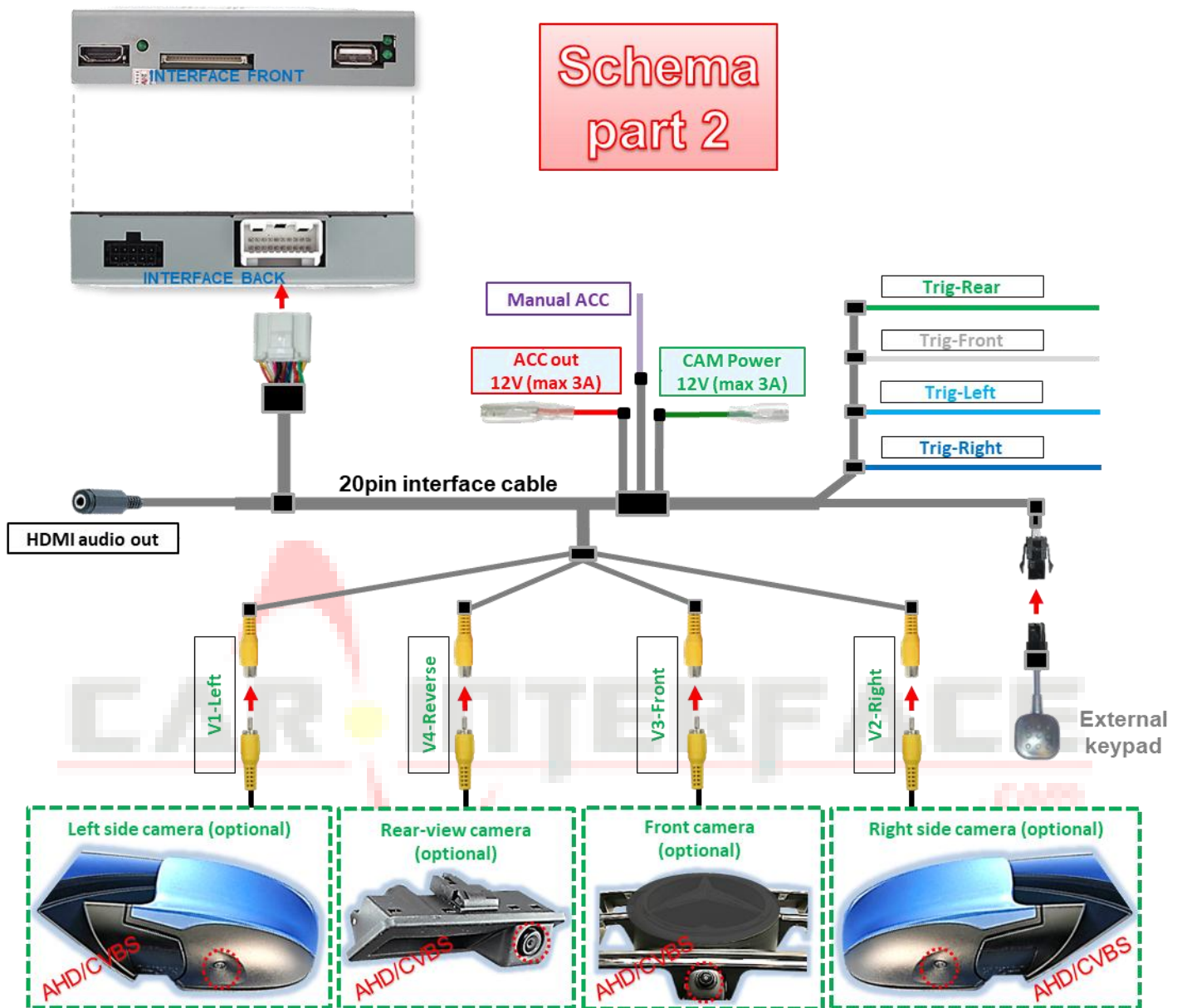

2.3 Installation – daughter PCB



- 1) The contact ends of ribbon cables must always be clipped in precisely on both sides at right angles, as even the slightest angle changes can lead to poor contact and short circuits.
- 2) The contact sides of ribbon cables must always correspond to the contact side of the connectors in terms of their installation position.



1

Carefully remove the black plastic rear cover of the CRONY2 all-in-one head unit. Then loosen the 5 screws on the head unit's metal cover and remove the metal cover.

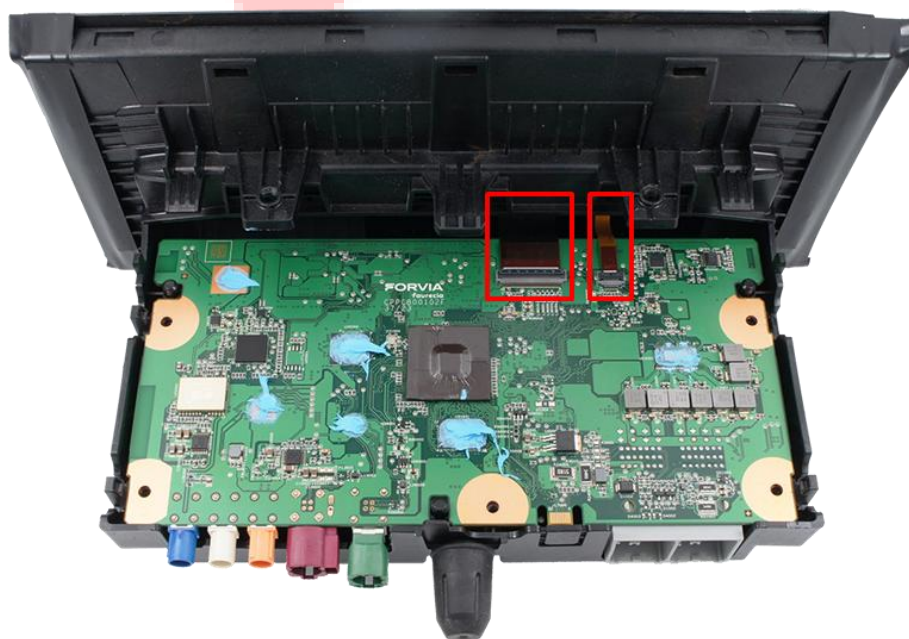

2

Unclip the two OEM ribbon cables coming from the monitor panel on the motherboard.

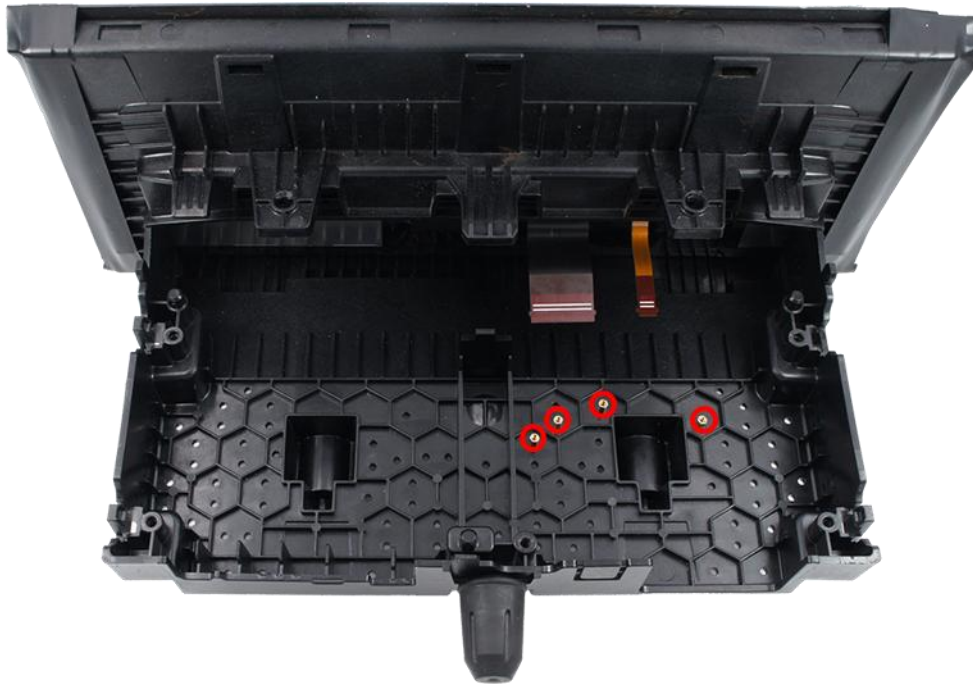

3

Insert the 4 spacers into the designated openings in the head unit's plastic housing and position them so that the daughter PCB will later rest against the centre plastic rib on the left (see the image under step 6).



4

Secure the 4 spacers on the back of the head unit using washers and nuts.



5

Snap the 40pin ribbon cable into the 40pin ribbon cable socket (PCB) on the daughter PCB.



6

Snap the 40pin OEM ribbon cable coming from the monitor panel into the 40pin ribbon cable socket (LCD) on the daughter PCB, then secure the daughter PCB to the four spacers using the screws.



7

Snap the 40pin ribbon cable into the free 40pin ribbon cable socket on the motherboard.

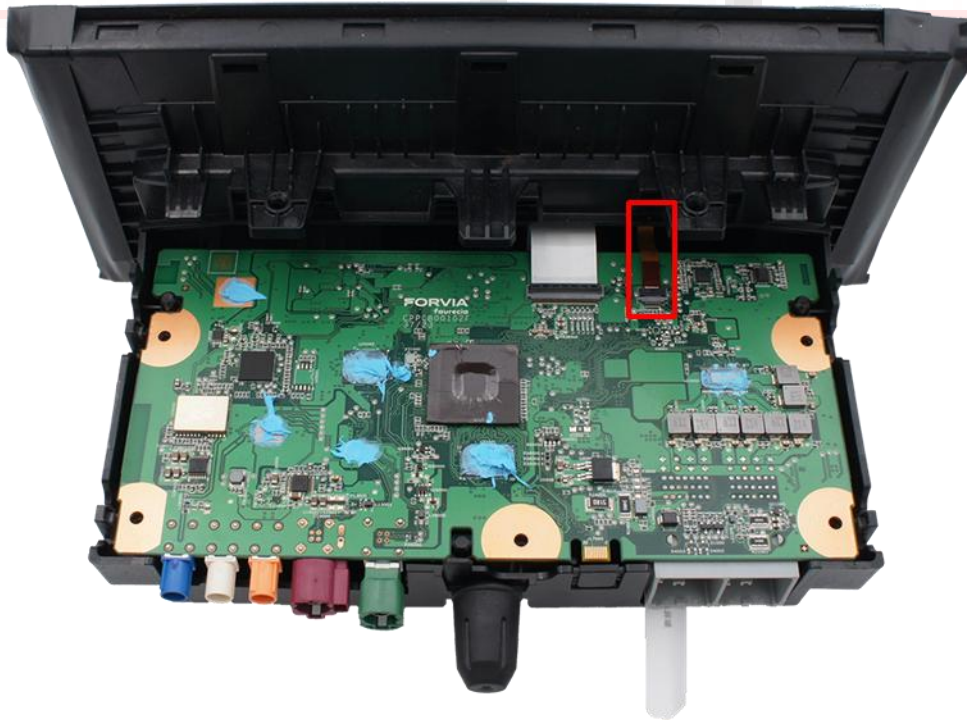

8

Reinsert the motherboard into the correct position and clip the narrow OEM ribbon cable coming from the monitor panel back into the free ribbon cable socket on the motherboard.



9

Route the 20pin picture signal cable out of the head unit housing at a suitable point.



10

Replace the metal cover on the head unit and secure it with the 5 screws.

2.4 Connection – picture signal cable

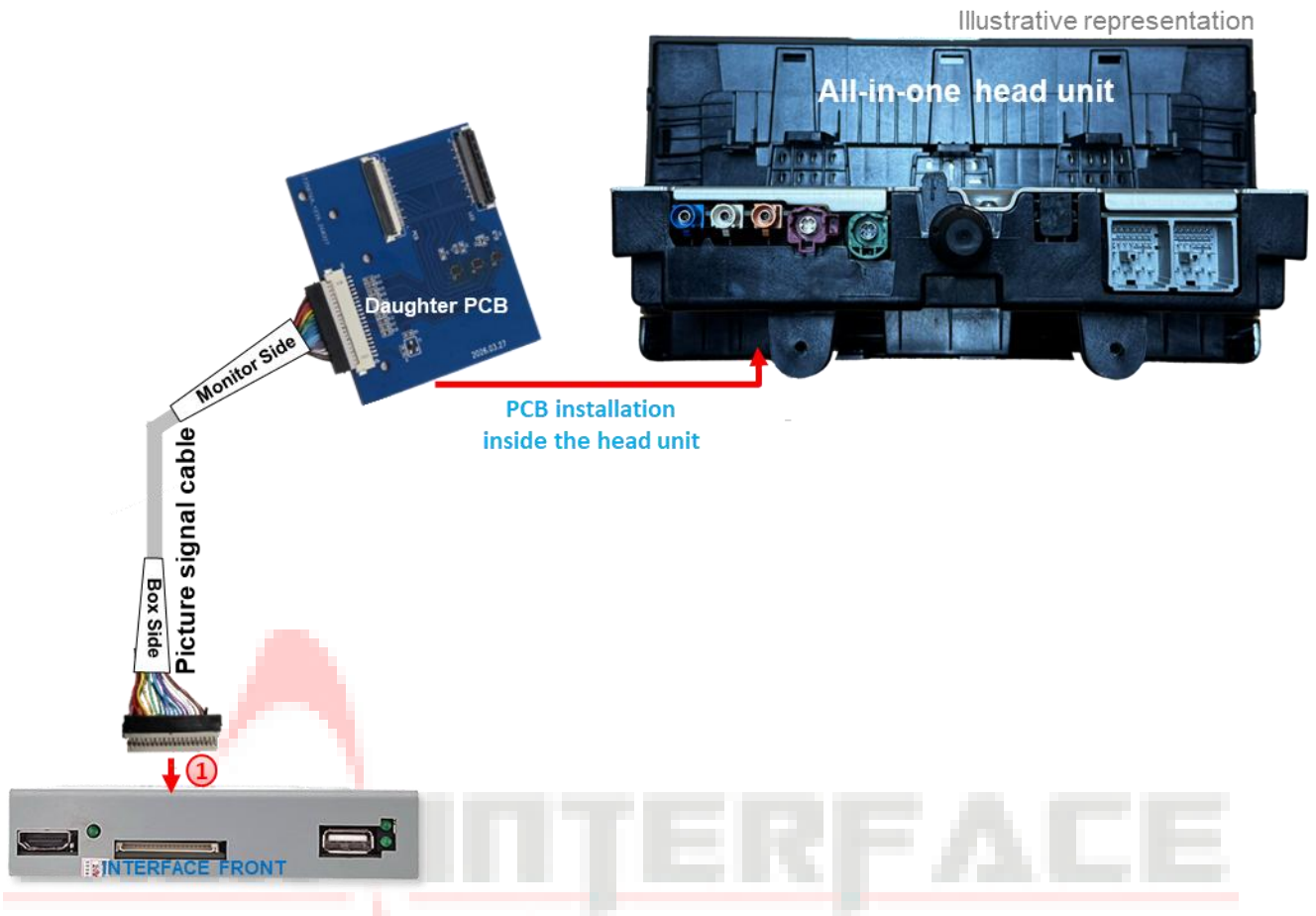

- 1 Connect the 20pin female connector "box side" of the picture signal cable pre-mounted on the daughter PCB to the 20pin male connector of the video interface.

2.5 Connection – Cable sets, power supply and CAN bus or analogue without CAN bus

The interface can be integrated via CAN bus or operated completely analogue without connection to the CAN bus.

When integrated via CAN bus, the interface is switched on via this and R-gear signal and turn signals are usually recognised from this. In some vehicles, movable guide lines can then also be displayed using the CAN bus steering signals.

In exceptional cases, CAN communication is not (fully) compatible. If no interface LED lights up after connecting the **10pin power/CAN cable set** with the ignition switched on, the analogue connection described below must be made. The analogue connection is also possible in order to avoid a possible subsequent CAN bus incompatibility. In this case, the interface must be switched on and switched to its inputs via +12V switch inputs.

The display of movable guide lines for the rear view camera is not available with an analogue connection.

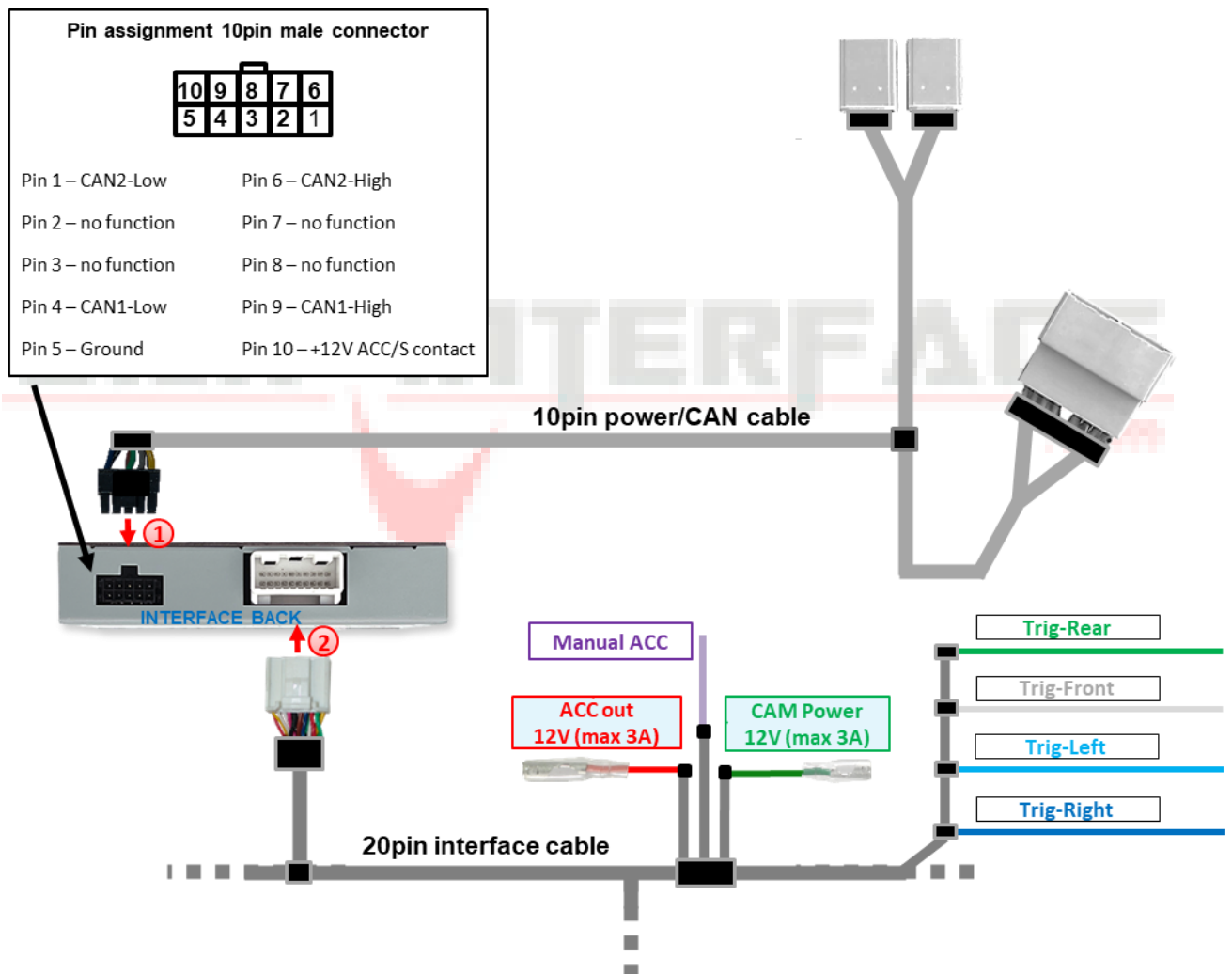

- 1 Connect the 10pin female connector of the **10pin power/CAN cable** to the 10pin male connector of the interface.
- 2 Connect the female connector of the **20pin interface cable** to the 20pin male connector of the interface.

2.5.1 Connection with CAN bus

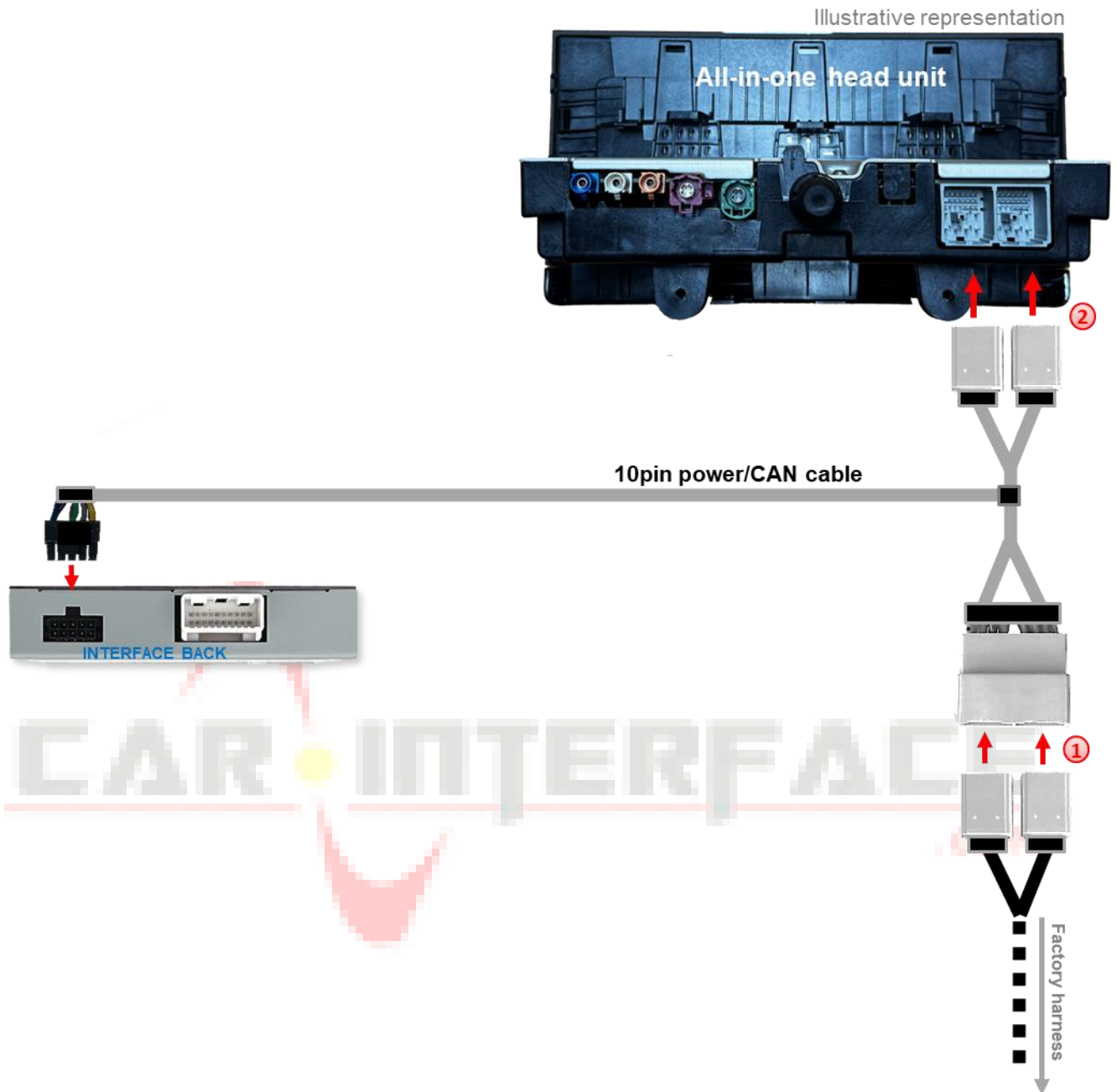

- 1 Disconnect the two female 28pin system connectors from the vehicle wiring harness at the rear of the head unit and connect them to the two male 28pin system connectors on the 10pin power/CAN cable.
- 2 Connect the two opposing female 28pin system connectors of the 10pin power/CAN cable to the previously exposed male 2x 28pin system connector on the head unit

Attention!
In exceptional cases, CAN communication may not be (fully) compatible. If, after connecting the 10-pin power/CAN cable set with the ignition is switched on, the interface LED, the analogue connection described below analogue connection described below.

2.5.2 Analogue connection without CAN bus

For analogue connection, the two CAN wires of the 10pin power/CAN cable are not connected – instead, the two wires of the 10pin power/CAN cable must be separated!

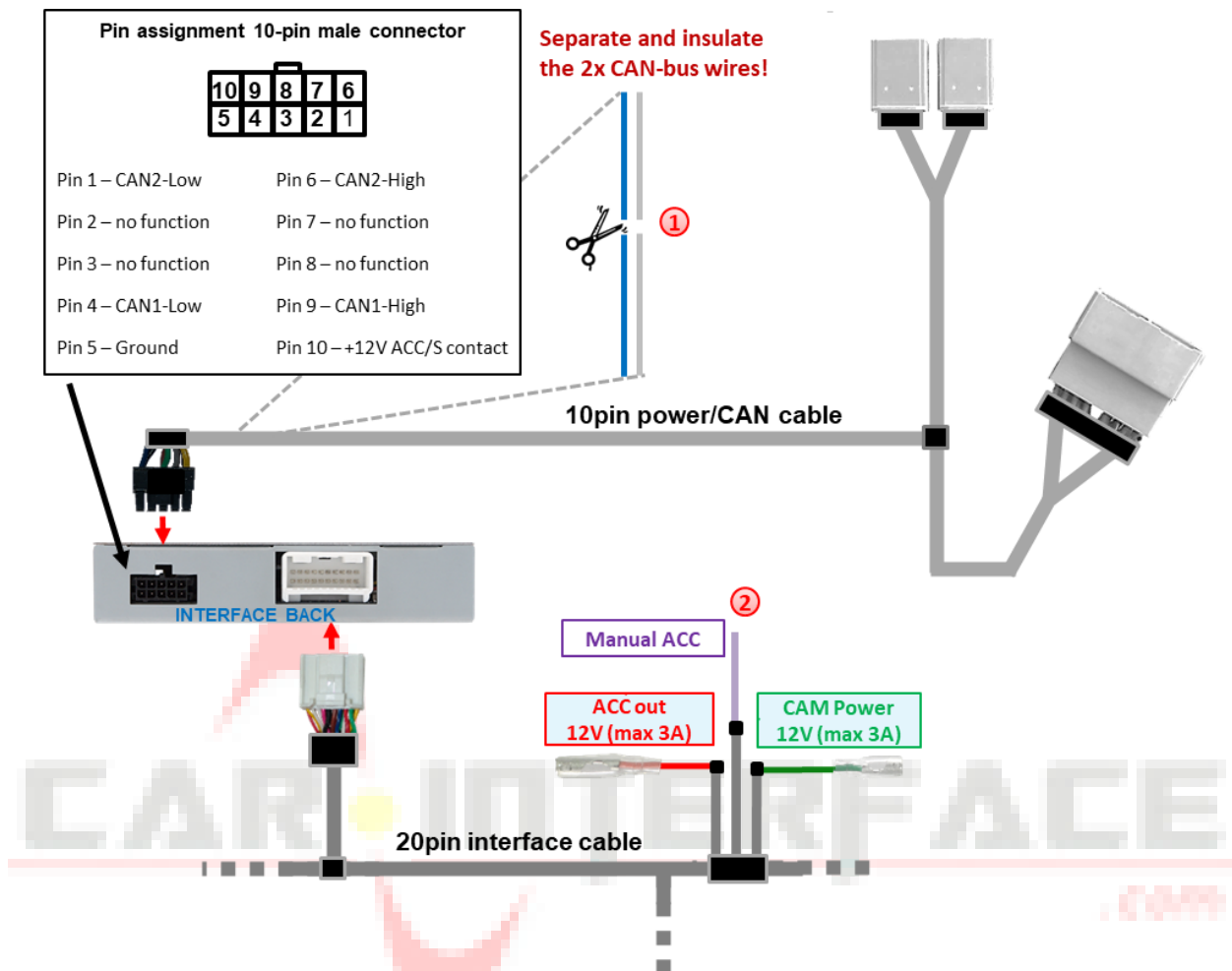

- ① Separate and insulate the two CAN bus wires (blue and grey) of the 20pin interface cable approx. 4-5 cm behind the black male connector.
- ② Connect the purple Manual ACC wire of the 20pin interface cable to the +12V S contact (terminal 86s) or ACC terminal 15r (e.g. cigarette lighter, glove compartment light).



Notes

- The screen is only switched on as long as the video interface is switched on via +12V to Manual ACC. Otherwise, the factory picture is also black. When selecting the switch-on signal, check whether the factory picture is available in all desired operating states.
- The display of movable guide lines is not available with an analogue connection.
- If the interface is connected via analogue (without CAN bus), the rear-view camera and side cameras must also be connected via analogue.
 See points:
 2.7.2 Case 2: Reverse gear signal from analogue signal
 2.9.2 Case 2: turn signals from analogue signal

2.6 Power supply outputs

The two **red** and **green** power supply cables **ACC out 12V (max 3A)** and **CAM Power 12V (max 3A)** of the **20pin interface cable** can be used either as an ACC power supply for the **V1-Left, V2-Right, V3-Front or HDMI input*** connected **external video sources** (e.g. iOS/Android devices, laptop, streaming stick, DVB-T2 tuner), or as a power supply for the **V1-Left, V2-Right, V3-Front, V4-Reverse** or HDMI input* (e.g. side, front and rear-view camera).

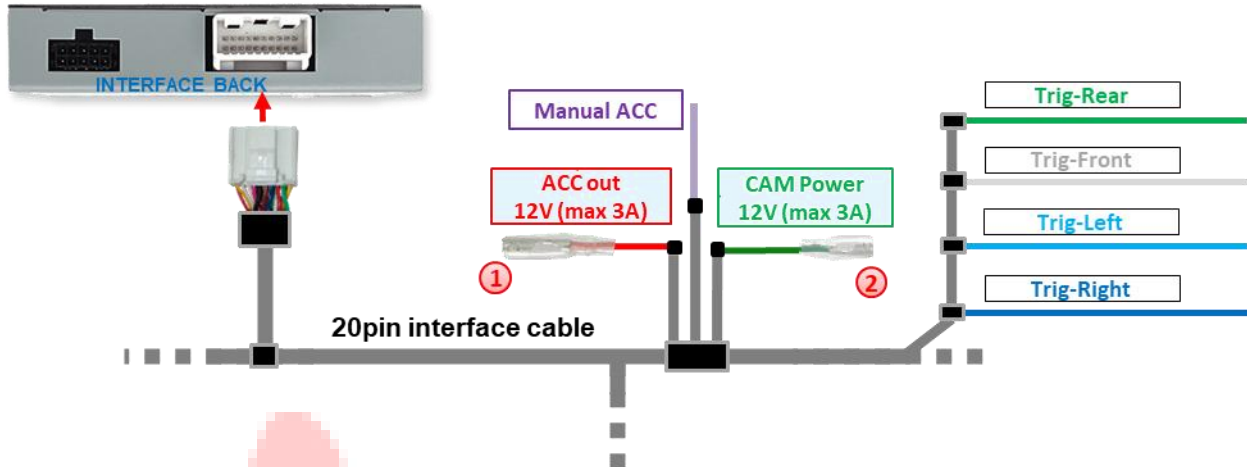

- ① **External video sources** (not cameras) can be powered via the red **ACC out 12V (max 3A)** power supply line of the 20pin interface cable. The wire carries a **permanent** +12V ACC switching output voltage while the interface is switched on (see the following chapters for connection diagrams).
- ② The power supply for **aftermarket cameras** (e.g. rear, side and front cameras) can be provided via the green power supply line **CAM Power 12V (max 3A)** of the 20pin interface cable. The wire carries **+12V switching output voltage** only as long as one of the camera inputs is displayed, regardless of whether the connection is made via the vehicle CAN bus or via one of the trigger cables (see the following chapters for connection diagrams).

* **HDMI input only available with HDV-CR2**

2.6.1 Connection and power supply - Video sources

Rear-view camera, front camera and 2 side cameras

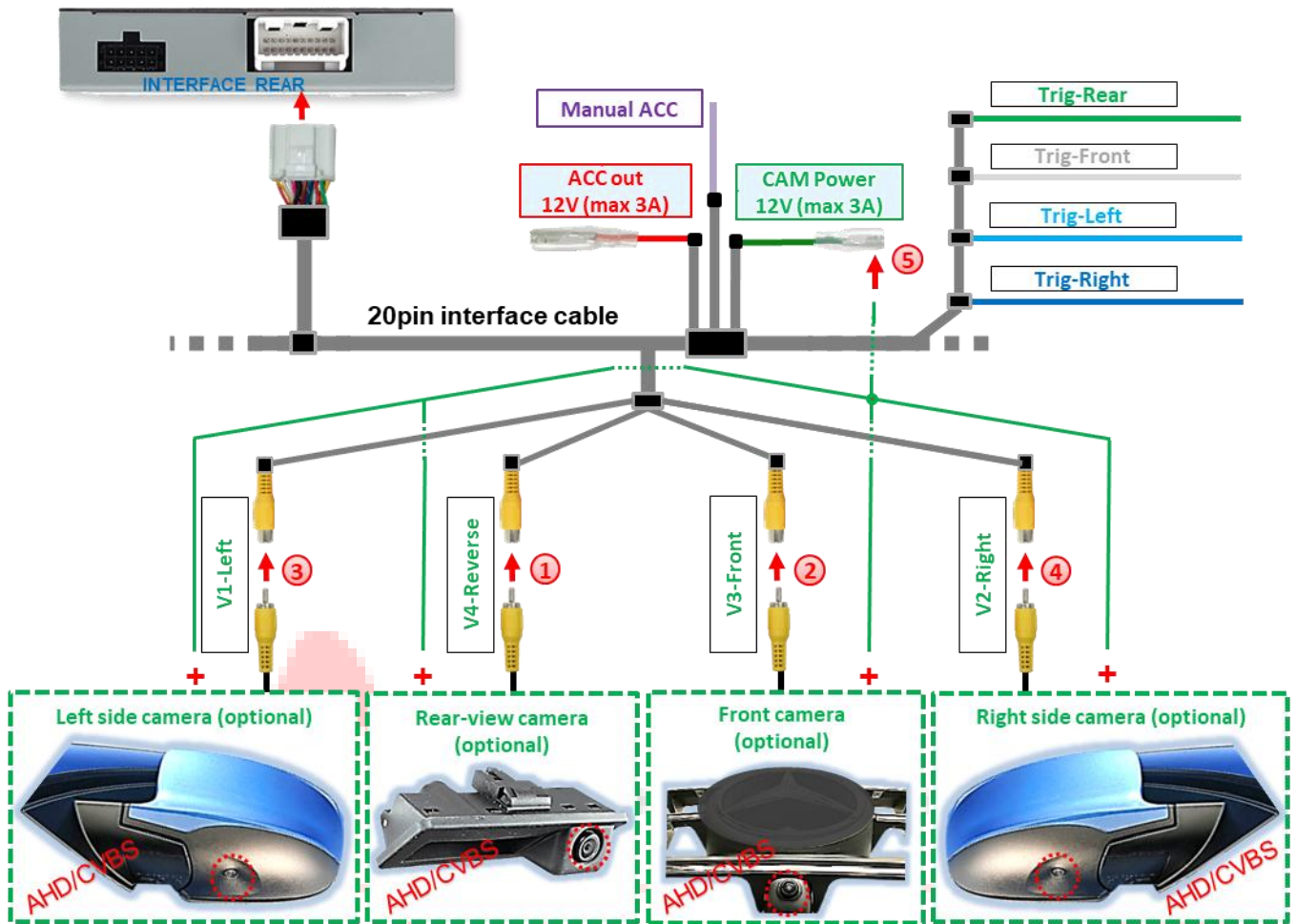

- ① Connect the RCA male connector of the rear-view camera to the RCA female connector **V4-Reverse** of the 20pin interface cable.
- ② Connect the RCA male connector of the front camera to the RCA female connector **V3-Front** of the 20pin interface cable.
- ③ Connect the RCA male connector of the left side camera to the RCA female connector **V1-Left** of the 20pin interface cable.
- ④ Connect the RCA male connector of the right side camera to the RCA female connector **V2-Right** of the 20pin interface cable.
- ⑤ Connect the power supply for all aftermarket cameras to **the green wire CAM Power 12V (max 3A)** of the 20pin interface cable.



Note: The type of camera selection (via vehicle CAN bus or trigger lines) can be preset individually for each input in the OSD menu settings **for** each input.

Attention!
The video signal type of each video source must be defined in the OSD menu of the corresponding video input.

2.6.2 Connection and power supply – video sources rear-view camera, front camera and 2 video sources

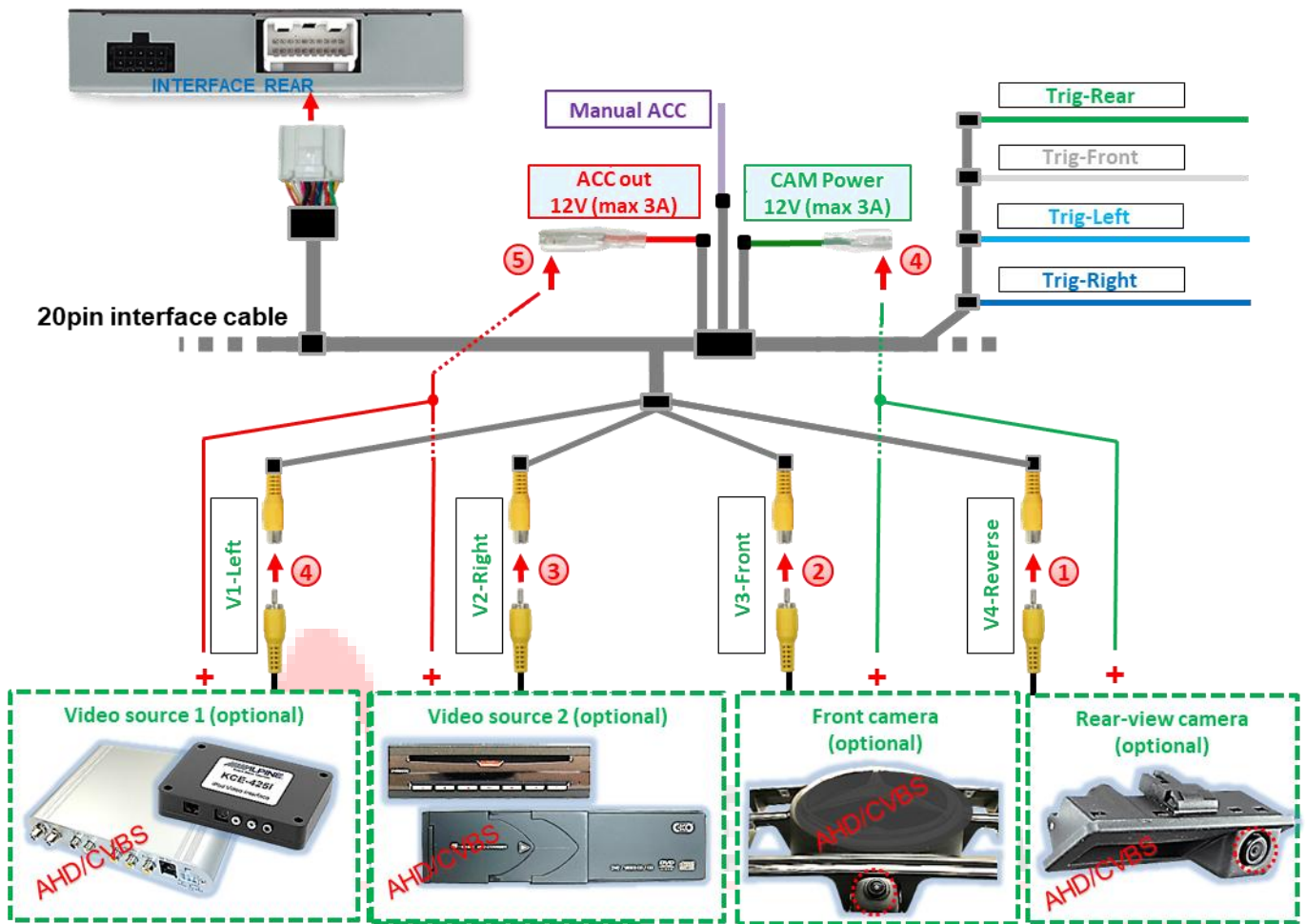

- ① Connect the RCA male connector of the rear-view camera to the RCA female connector **V4-Reverse** of the 20pin interface cable .
- ② Connect the RCA male connector of the front camera to the RCA female connector **V3-Front** of the 20pin interface cable.
- ③ Connect the RCA male connectors of video sources 1 and 2 to the RCA female connectors **V1-Left** and **V2-Right** of the 20pin interface cable.
- ④ Connect the power supply for aftermarket cameras to **the green wire of the CAM Power 12V (max 3A)** of the 20pin interface cable.
- ⑤ Connect the power supply for video sources to **the red wire ACC out 12V (max 3A)** of the 20pin interface cable.



Note: The type of camera selection (via vehicle CAN bus or trigger lines) can be preset individually for each input in the OSD menu settings **individually** preset for each input.

Attention!
The video signal type of each video source must be defined in the OSD menu of the corresponding video input.

2.7 Aftermarket rear-view camera

Automatic switching to the rear-view camera can be done via the CAN bus or an analogue reverse gear signal.

2.7.1 Case 1: Reverse gear signal from CAN bus

The basic requirement is that the interface connection has been made with the CAN bus. Furthermore, the vehicle CAN bus reverse gear signal and detection by the interface must be compatible. The interface then supplies +12V on the **green wire CAM Power 12V (max 3A)** of the 20pin interface cable while reverse gear is engaged, and the interface automatically switches to the rear-view camera input **V4-Reverse** or the **HDMI input***. See also chapter 1.4 Settings – 8 dip switch bench (interface functions).

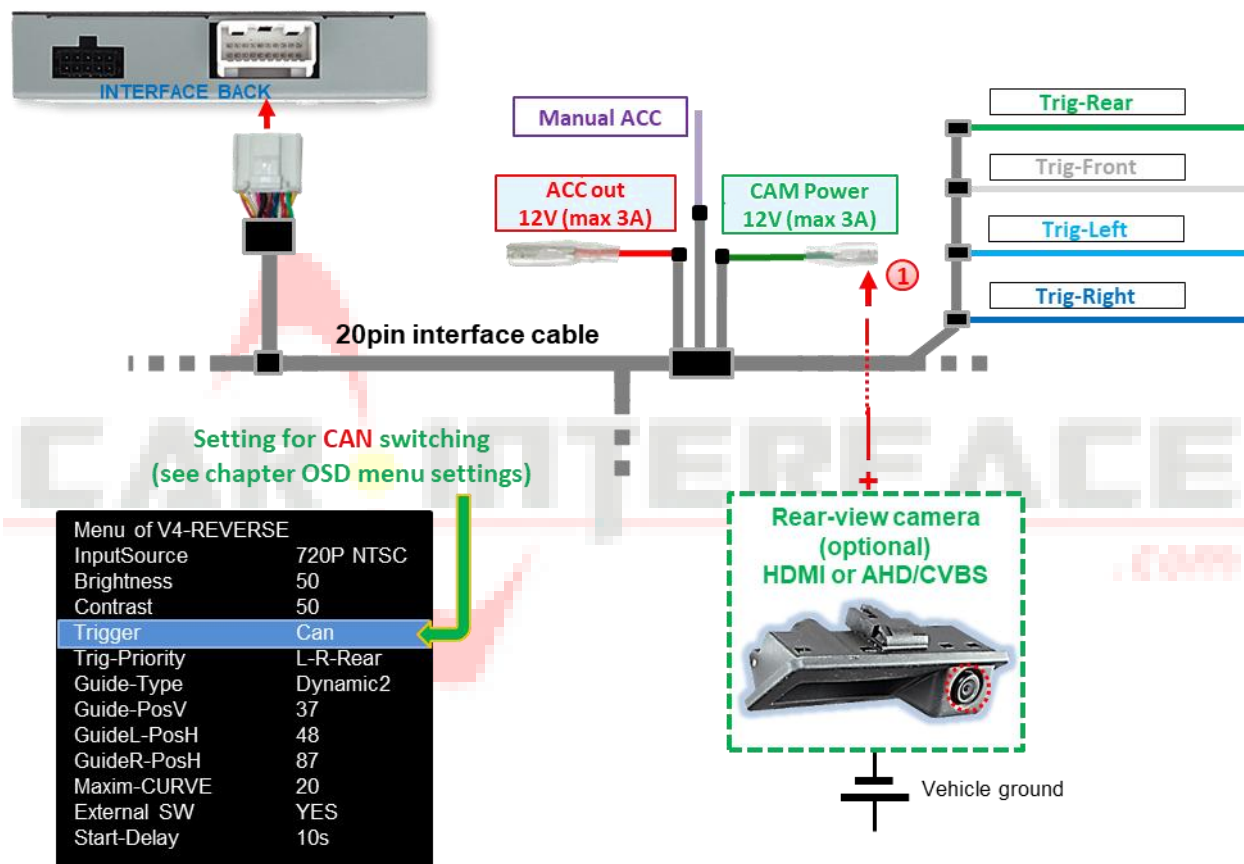

- 1 The +12V power supply for the aftermarket rear-view camera can be provided via the **green wire CAM Power 12V (max 3A)** of the 20pin interface cable, as this wire only carries current when camera inputs are switched on (some cameras are not stable under continuous current).



Notes

- If the **HDMI input*** is defined as the rear-view camera input, the **V4 reverse** input will have no function!
- If the reverse gear detection of the interface on the CAN bus does not work, the reverse gear signal must be connected in an analogue manner.

* **HDMI input only available with HDV-CR2**

2.7.2 Case 2: Reverse gear signal from analogue signal

If the interface is connected without CAN bus or if the interface does not supply +12V to the **green CAM Power 12V (max 3A) wire** of the 20pin interface cable while reverse gear is engaged (not all vehicles are compatible), an external switch signal from the reversing light is required. As the reversing signal contains electronic interference, a normally open relay (e.g. AC-MR-312 or AC-MR-201) or a noise filter (e.g. AC-PNF-RVC) is required. The following diagram shows the use of a normally open relay.

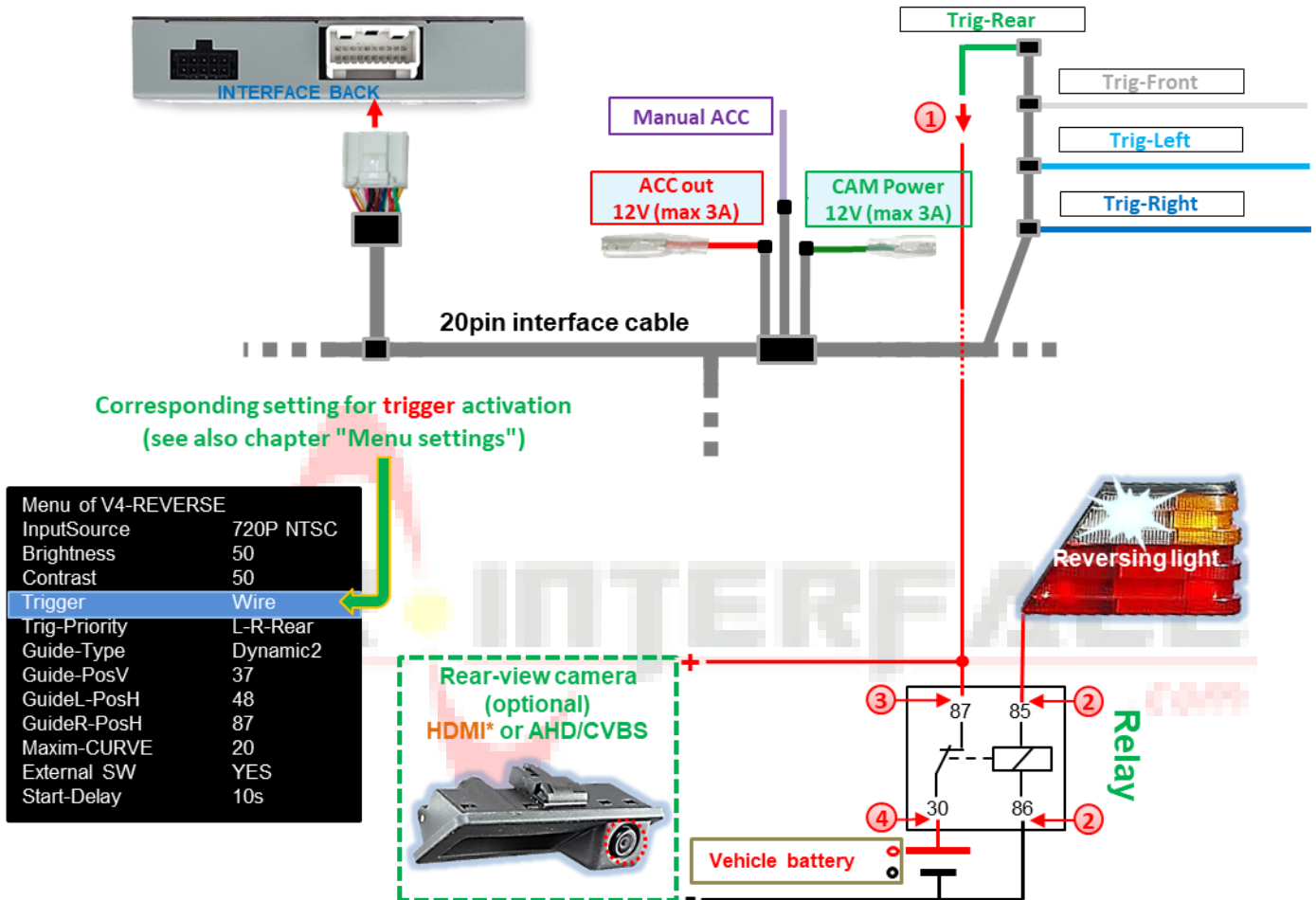

- 1 Connect the **green wire Trig-REAR** to the output terminal (87) of the relay.
- 2 Connect the reversing light power cable to the switching coil terminal (85) and the vehicle ground to the switching coil terminal (86) of the relay.
- 3 Connect the rear-view camera power supply wire to the output terminal (87) of the relay, in addition to the **green Trig-REAR wire**.
- 4 Connect the +12V continuous power supply to the input terminal (30) of the relay.



Note: For analogue connection, set the "Trigger" menu item to "Wire" in the OSD menu!

* HDMI input only available with HDV-CR2

2.8 Aftermarket front camera

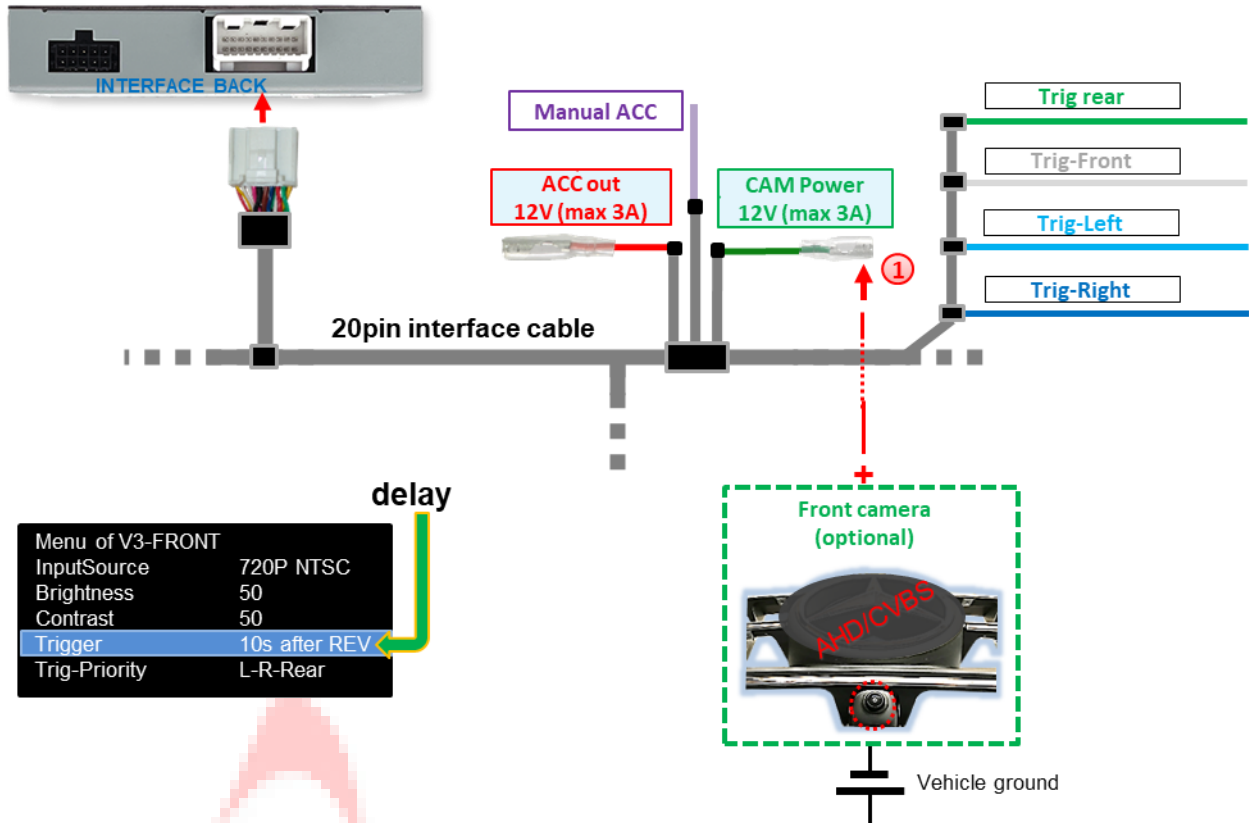

1 The **green wire CAM Power 12V (max. 3A)** can be used to power the front camera (and all other cameras connected to the video inputs). This only carries current for the duration of any camera activation (some cameras are not stable with continuous current). The prerequisite is that Dip 3 = **ON** (black 8 dip switch bench). The **green wire** then supplies +12V (max. 3A) as power for the front camera as long as the front camera input is displayed. The delay time can be individually selected for **5, 10, 15** or **20** seconds in the OSD menu settings of the front camera.

Switching to the front camera after reverse gear is engaged for the time set in the OSD menu occurs when a reverse gear signal is received from the CAN bus and with an analogue connection.



Note: In addition, manual switching to the front camera input (short press) is possible from any picture mode via an external keypad (see chapter 3 *Operating the video interface*).

2.9 Aftermarket side cameras

Side cameras can be connected via CAN bus or analogue selection.

2.9.1 Case 1: Turn signals from CAN bus

The basic requirement is that the interface connection has been made with CAN bus. Furthermore, vehicle CAN bus turn signals and their detection by the interface must be compatible. Then, for the duration of a turn signal operations, +12V is applied to the **green CAM Power 12V (max 3A) wire** of the 20pin interface cable.

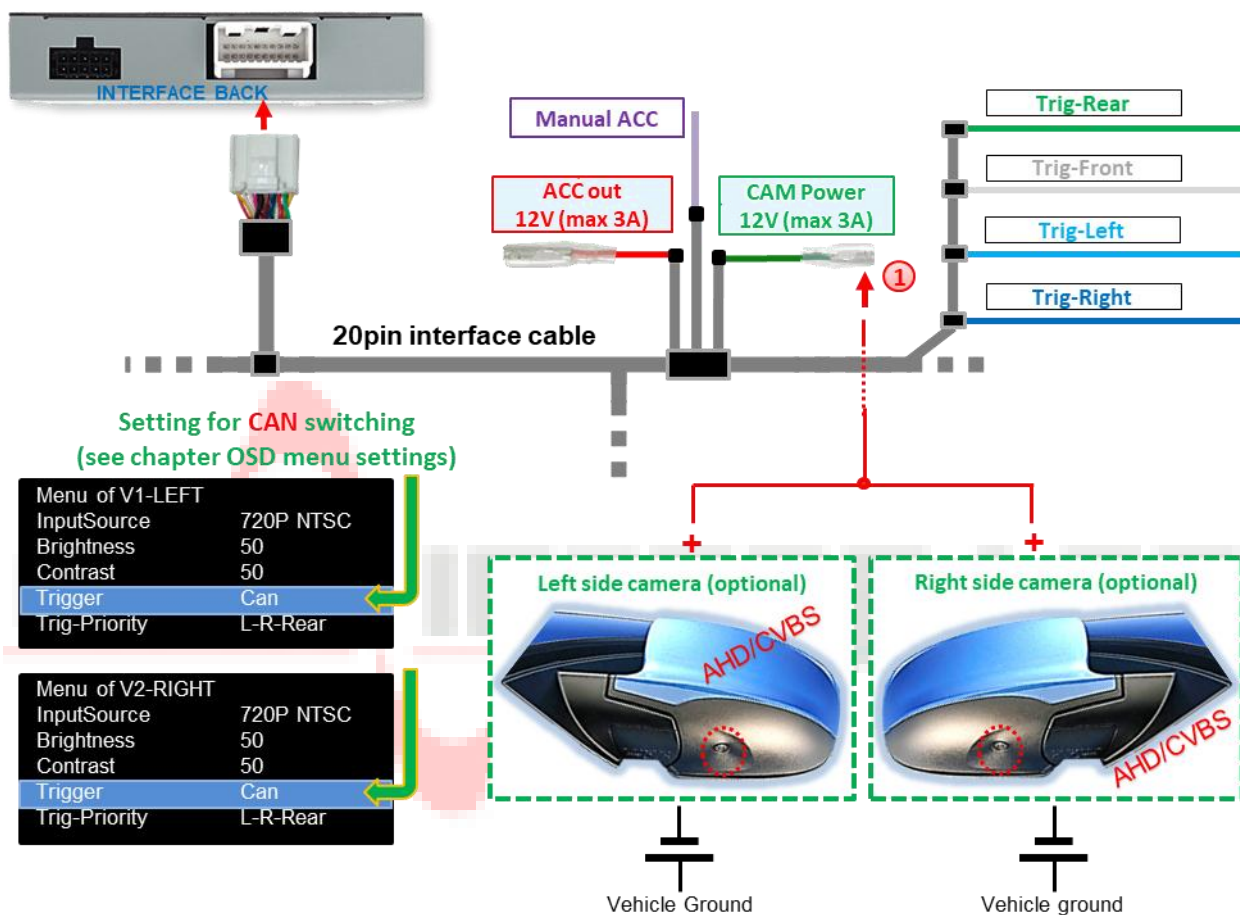

- 1 Power for the side cameras can be supplied via **the green CAM Power 12V wire (max 3A)** of the 20pin interface cable, as this wire only carries current when the camera is activated (some cameras are not stable under continuous current).

Note: If the interface's flashing signal detection on the vehicle CAN bus does not work, the turn signals must be connected analogue.

2.9.2 Case 2: turn signals from analogue signal

If the interface is connected without a CAN bus, or if the turn signals from the vehicle CAN bus are not recognised when the interface is connected with a CAN bus, analogue activation of the side camera inputs is possible via the +12V switching input lines **Trig-Left** and **Trig-Right**. An external switching signal from the turn signal bulbs is required to switch to the side camera inputs. Since turn signals may contain electronic interference, a normally open relay (e.g. AC-RW-1230 with AC-RS5 cabling) or a noise filter (e.g. AC-PNF-RVC) is required for each input. The diagram below shows the use of a normally open relay.

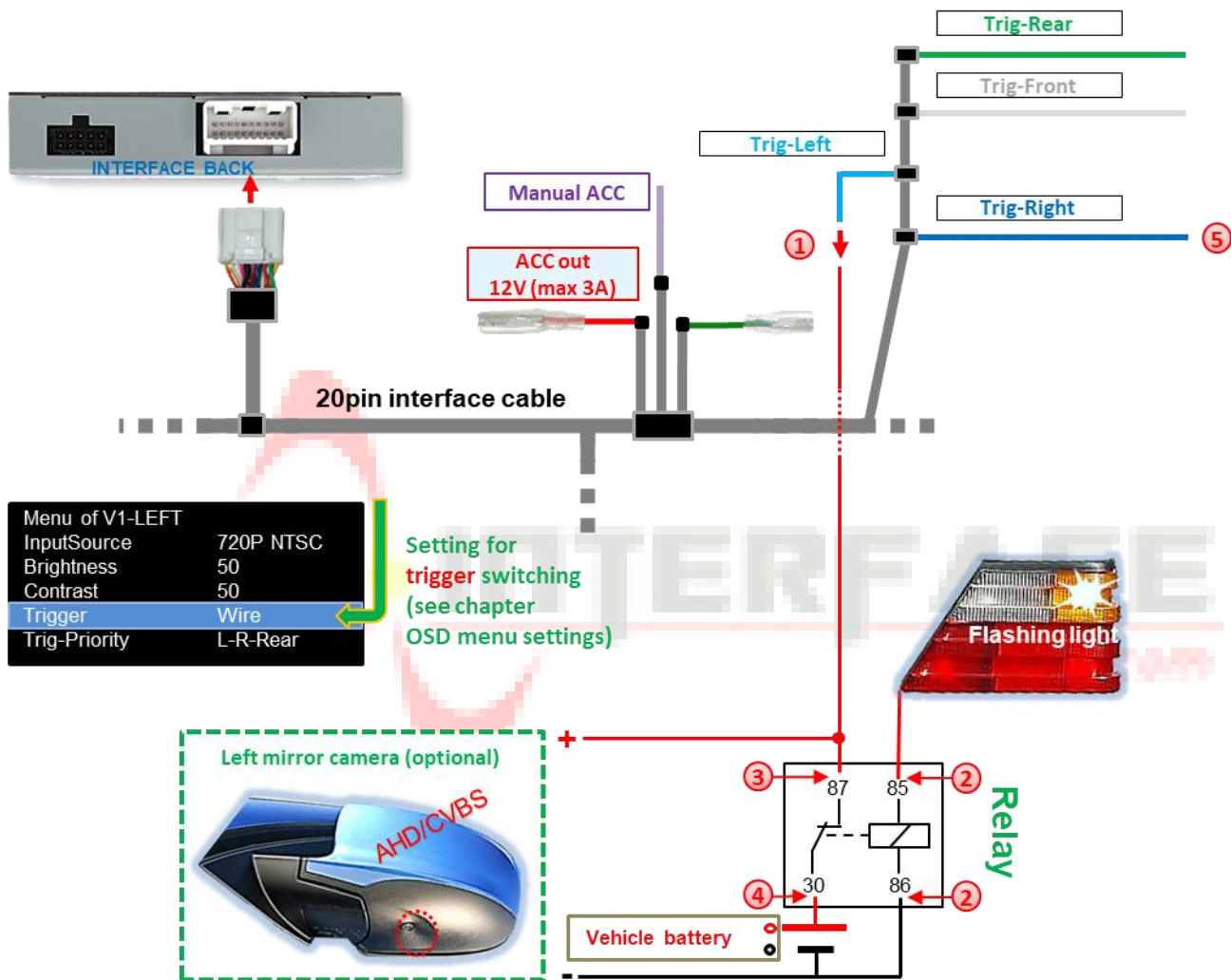

- ① Connect the light blue wire **Trig-Left** to the output terminal (87) of the relay.
- ② Connect the indicator cable of the left indicator to the relay's switching coil terminal (85) and the vehicle ground to the relay's switching coil terminal (86).
- ③ Connect the left side camera power cable to the output terminal (87) of the relay, in addition to the light blue wire **Trig-Left**.
- ④ Connect the +12V continuous current to the input terminal (30) of the relay.
- ⑤ The same connection method applies to the right side camera via the dark blue **Trig-Right** wire.

2.10 HDMI rear-view camera or other HDMI sources (HDV-CR2 only)

HDMI input* of the interface can generally be used for any video source with an HDMI output (e.g. rear-view camera, 360° camera system or other video sources such as smartphones, laptops, streaming sticks, DVB-T2 tuners, etc.).

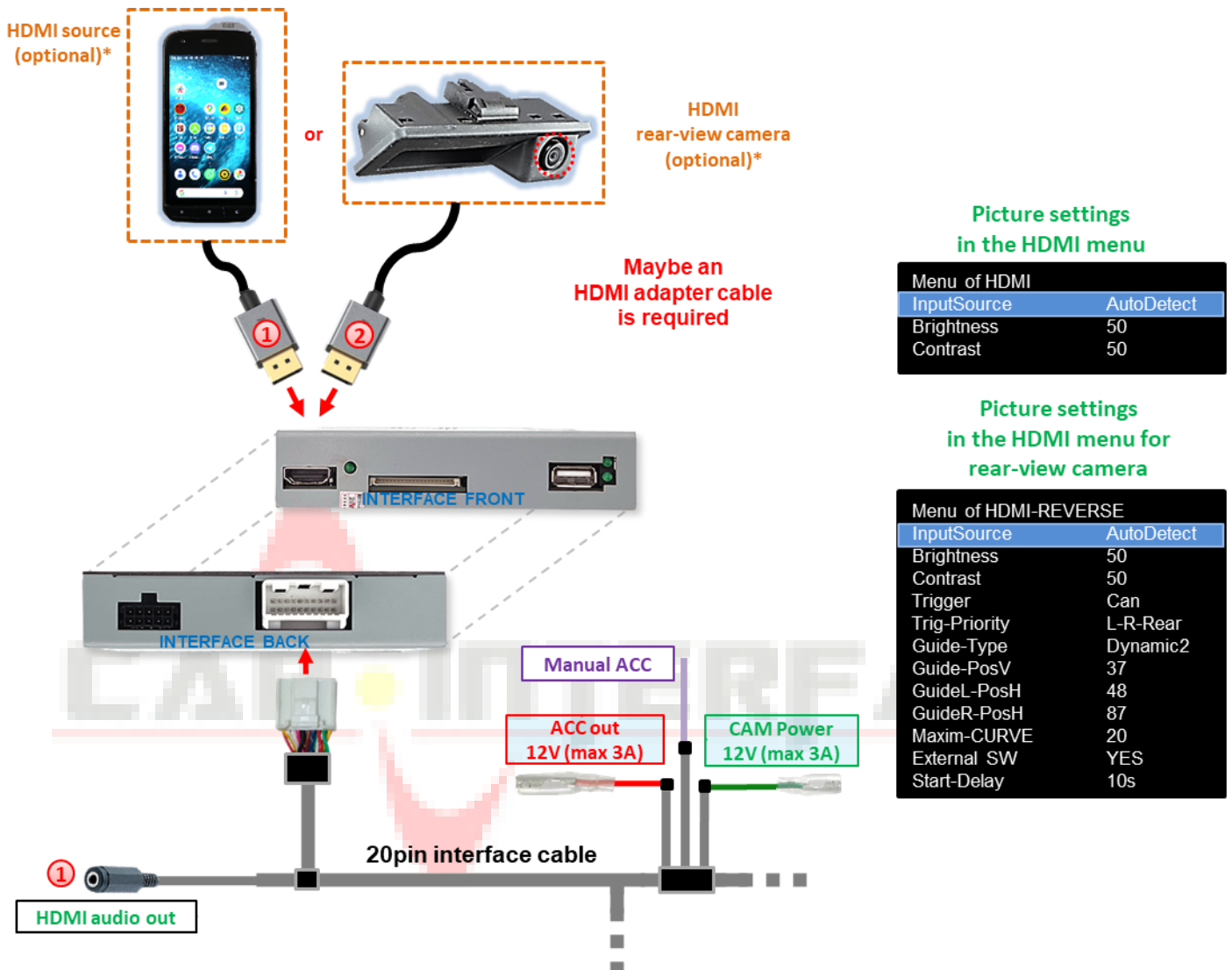

Picture settings in the HDMI menu

Menu of HDMI	
InputSource	AutoDetect
Brightness	50
Contrast	50

Picture settings in the HDMI menu for rear-view camera

Menu of HDMI-REVERSE	
InputSource	AutoDetect
Brightness	50
Contrast	50
Trigger	Can
Trig-Priority	L-R-Rear
Guide-Type	Dynamic2
Guide-PosV	37
GuideL-PosH	48
GuideR-PosH	87
Maxim-CURVE	20
External SW	YES
Start-Delay	10s

- 1 If an optional HDMI video source is connected to the **HDMI input***, the picture displayed on the source's display (e.g. smartphone, laptop, etc.) is mirrored on the vehicle monitor. Other sources (e.g. streaming stick, DVD player, DVB-T tuner, etc.) can also be played back on the vehicle monitor. The video source can be powered via the **red wire ACC out 12V (max. 3A)**. Received audio signals will only be supplied via the 3.5 mm jack socket **HDMI audio out *** of the 20pin interface cable. (See the following chapter 2.11 Audio insertion .)
- 2 If a rear-view camera or a 360° camera system is connected to the **HDMI input*** (activated via CAN bus or analogue), the picture from the rear-view camera is displayed when reverse gear is engaged, and after disengagement, the picture from a front camera connected to **the V3 front camera** input is also displayed for the preset time. Power can be supplied via the **green wire CAM Power 12V (max 3A)**.

* **HDMI input only available with HDV-CR2**

2.11 Audio insertion

The interface can only insert video signals into the factory infotainment system. For all connected AV sources, their audio output must be connected to the factory AUX input (if available) or an optional audio feeder (e.g. FM modulator).

Audio signals from the **HDMI input*** are output via the interface's 3.5 mm jack socket **HDMI audio out**. In this case, the interface's **HDMI audio out** must be connected to the factory AUX input (if available) or an optional audio feeder (e.g. FM modulator).

If several AV sources are connected to the infotainment system, an additional audio switch may be necessary. Input video signals can be activated in parallel with any audio mode of the factory infotainment system.

*** HDMI input only available with HDV-CR2**

2.12 Connection – video interface and external keypad

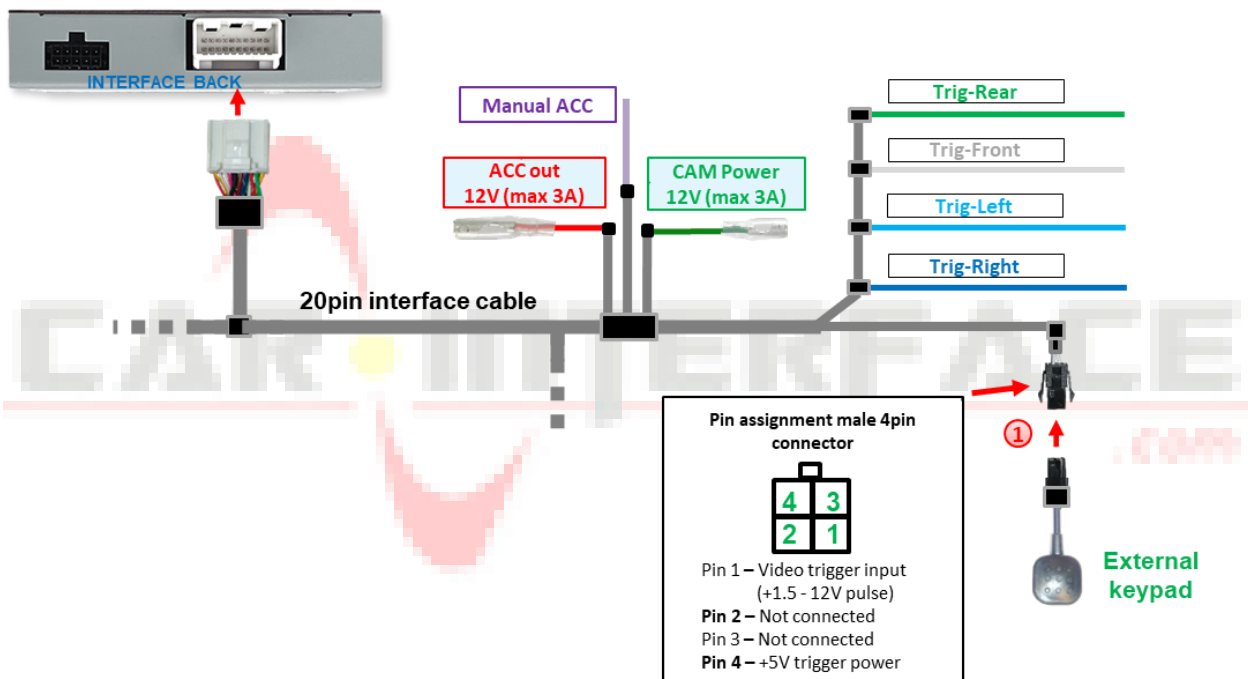

- 1 Connect the 4pin female connector of the external keypad to the 4-pin male connector of the 20pin interface cable.



Note: Even if the keypad is not required for switching between multiple sources, it is strongly recommended that the keypad be connected and remain hidden on the interface. The keypad should not be installed in a "pressed" position.

Optional: Instead of the external keypad, the interface can also be operated using the optionally available "HDA-RC" remote control.* This allows direct selection of the video/camera inputs and more convenient changing of the settings in the respective OSD menus.

* The remote control is compatible with all HDA and HDV interfaces that are marked with "RC" at the end of the software version.



"HDA-RC" remote control optionally available

2.13 settings OSD menu

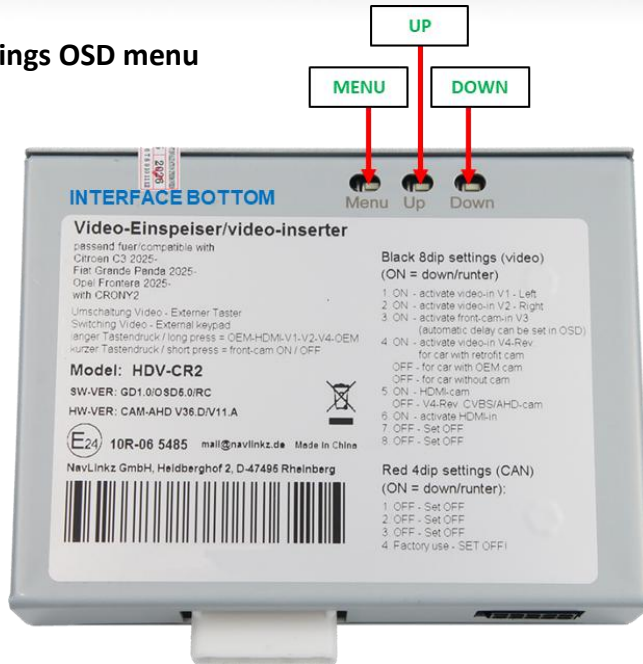

Attention!
The video signal type for each video source must be defined in the OSD menu for the corresponding video input.

OSD menu settings can be changed using the 3 keys on the rear of the interface. MENU opens the OSD settings menu or moves the cursor to the next menu item. UP and DOWN change the values of the current menu item.



The individual OSD settings menu for each video input can only be accessed while it is displayed, regardless of whether a video source is connected.

The following settings are available in the OSD settings menus of the 5 video inputs:

Menu **V1-Left (V2-Right)** — 8pin DIP switch bench DIP 1 (DIP 2) = ON

Input Source Video input signal type for video source connected to **V1-Left (V2-Right)**. This **must** be defined for correct image reproduction. The following video source signal types can be selected:
 CVBS video sources: **NTSC, PAL**
 AHD video sources: **720p NTSC, 960p NTSC, 1080p NTSC, 720p PAL, 960p PAL, 1080p PAL**

Menu of V1-LEFT	
InputSource	720P NTSC
Brightness	50
Contrast	50
Trigger	Can
Trig-Priority	L-R-Rear

Brightness Brightness
Contrast Contrast
Trigger Type of selection for video input **V1-Left (V2-Right)**

Menu of V2-RIGHT	
InputSource	720P NTSC
Brightness	50
Contrast	50
Trigger	Can
Trig-Priority	L-R-Rear

"CAN" function for side cameras via CAN bus. Selection of video input **V1-Left (V2-Right)** when the left (right) turn signal is activated. This requires that the turn signal is recognised by the interface on the vehicle CAN bus. Manual selection of this input via an external keypad does not work with this setting.
"Wire" function for other video sources or side cameras without CAN bus. Selection of video input **V1-Left (V2-Right)** is only possible via the **light blue (dark blue) Trig-Left (Trig-Right)** wire or manually via an external keypad.

Trig priority Priority of switching when switch signals are present for several inputs at the same time (CAN bus or analogue +12 V trigger). The signal with the highest priority is displayed:
L-R-Rear: V1-Left → V2-Right → V4-Reverse
Rear-R-L: V4-Reverse → V2-Right → V1-Left

V3 front menu

8 dip switch bench DIP 3 = ON

Input Source Video input signal type for video source connected to **V3 front**. This **must** be defined for correct image reproduction. The following video source signal types can be selected:

CVBS video sources: **NTSC, PAL**

AHD video sources: **720p NTSC, 960p NTSC, 1080p NTSC, 720p PAL, 960p PAL, 1080p PAL**

Brightness Brightness

Contrast Contrast

Trigger Type of selection for video input **V3 front**.

Delay function for front camera. The delay setting determines the automatic switching of a front camera connected to the V3 front input after reverse gear is engaged, as well as its display duration on the screen. Available 5s after REV, 10s after REV, 15s after REV, 20s after REV.

"Wire" function for other video sources. If a video source other than a front camera is to be connected to **V3 front**, select the "Wire" setting. This deactivates the "Delay" function and the input can only be selected via the **white Trig-Front** wire or manually via an external keypad.

Trig priority Priority of switching when switch signals are present for several inputs at the same time (CAN bus or analogue +12 V trigger). The signal with the highest priority is displayed:

L-R-Rear: **V1-Left** → **V2-Right** → **V4-Reverse**

Rear-R-L: **V4-Reverse** → **V2-Right** → **V1-Left**

Menu of V3-FRONT	
InputSource	720P NTSC
Brightness	50
Contrast	50
Trigger	10s after REV
Trig-Priority	L-R-Rear



V4-Reverse menu **8 dip switch bench** Dip 4 = ON, Dip 5 = OFF, Dip 6 = OFF

V4 reverse input has no function if **HDMI input*** is defined as the rear-view camera input (Dip 5 = ON).

Input Source	Video input signal type for video source connected to V4-Reverse . This must be defined for correct image reproduction. The following video source signal types can be used: CVBS video sources: NTSC, PAL AHD video sources: 720p NTSC, 960p NTSC, 1080p NTSC, 720p PAL, 960p PAL, 1080p PAL
Brightness	Brightness
Contrast	Contrast
Trigger	Type of selection for rear-view camera input V4 reverse . "CAN" function with CAN bus connection. With the "CAN" setting, the system automatically switches to V4 Reverse for CVBS/AHD rear-view camera when reverse gear is engaged. This requires the interface to recognise reverse gear in the CAN bus. "Wire" function with analogue connection. A rear-view camera connected to V4 Reverse can be selected via the green Trig Left wire using both the "Wire" and "CAN" settings. It is recommended to set "Wire" for analogue (reversing signal) connections.
Trig priority	Priority of switching when switch signals are present for several inputs at the same time (CAN bus or analogue +12 V trigger). The signal with the highest priority is displayed: L-R-Rear: V1-Left → V2-Right → V4-Reverse Rear-R-L: V4-Reverse → V2-Right → V1-Left
Guide Type	Setting of 6 different angles for the guide lines for the rear-view camera Movable guide lines Dynamic 1-6 Fixed guide lines Fixed 1-6 No guide lines OFF
Guide Pos. V	Vertical position of the guide lines 35-69
Guide L Pos.H	Horizontal position of the left guide line 00-90
Guide R Pos.H	Horizontal position of the right guide line 00-121
Maximum CURVE	Radius of the guide lines 01
External SW	Selectable via external keypad V4 Reverse YES: <i>Factory video → HDMI* → V1-Left → V2-Right → V4-Reverse → Factory video</i> NO: <i>Factory video → HDMI* → V1-Left → V2-Right → Factory video</i>
Start delay	Switching delay of the interface at start-up. This function is technically necessary in some vehicles, as otherwise malfunctions of the factory system may occur (e.g. black screen, touch problems). The following options are available (in seconds): 5s/6s/7s/8s/9s/10s/12s/15s/20s Changing the default settings may lead to malfunctions!

Menu of V4-REVERSE	
InputSource	720P NTSC
Brightness	50
Contrast	50
Trigger	Can
Trig-Priority	L-R-Rear
Guide-Type	Dynamic2
Guide-PosV	37
GuideL-PosH	48
GuideR-PosH	87
Maxim-CURVE	20
External SW	YES
Start-Delay	10s

*** HDMI input only available with HDV-CR2**

HDMI menu*

8 dip switch bench (DIP 4 = ON, DIP 5 = **ON/OFF**, DIP 6 = ON)

HDMI AV input (Dip 5 = OFF)

InputSource The picture resolution of connected HDMI sources is automatically detected.

Brightness Brightness

Contrast Contrast

Menu of HDMI	
InputSource	AutoDetect
Brightness	50
Contrast	50

HDMI rear-view camera input (Dip 5 = ON)

InputSource The picture resolution of connected HDMI sources is automatically detected.

Brightness Brightness

Contrast Contrast

Trigger Type of selection for rear-view camera input **HDMI-REV**.

Menu of HDMI-REVERSE	
InputSource	AutoDetect
Brightness	50
Contrast	50
Trigger	Can
Trig-Priority	L-R-Rear
Guide-Type	Dynamic2
Guide-PosV	37
GuideL-PosH	48
GuideR-PosH	87
Maxim-CURVE	20
External SW	YES
Start-Delay	10s

"CAN" function with CAN bus connection. With the "CAN" setting, the system automatically switches to **HDMI*** for the HDMI rear-view camera when reverse gear is engaged. This requires the interface to recognise reverse gear in the CAN bus.

"Wire" function with analogue connection. A rear-view camera connected to **HDMI*** can be selected via the **green Trig Rear wire** using either the "Wire" or "CAN" setting. We recommend setting "Wire" for analogue (reversing signal) connections.

Trig priority Priority of switching when switch signals are present for several inputs at the same time (CAN bus or analogue +12 V trigger). The signal with the highest priority is displayed:

L-R-Rear: V1-Left → V2-Right → V4-Reverse
Rear-R-L: V4-Reverse → V2-Right → V1-Left

Guide Type Setting of 6 different angles for the guide lines for the rear-view camera

Movable guide lines **Dynamic 1-6**
 Fixed guide lines **Fixed 1-6**
 No guide lines **OFF**

Guide pos. V Vertical position of guide lines **35-69**

Guide L Pos.H Horizontal position of the left guide line **0**

Guide R Pos.H Horizontal position of the right guide line **00-121**

Maximum curve Radius of the guide lines **01-20**

External SW Selectable via external keypad **V4 Reverse**

YES: Factory video → **HDMI*** → **V1-Left** → **V2-Right** → **V4-Reverse** → Factory video

NO: Factory video → **HDMI*** → **V1-Left** → **V2-Right** → Factory video

Start delay Switching delay of the interface at start-up. This function is technically necessary in some vehicles, as otherwise malfunctions of the factory system may occur (e.g. black screen, touch problems). The following options are available (in seconds):

5s/6s/7s/8s/9s/10s/12s/15s/20s

Changing the default settings may lead to malfunctions!

Notes: **V4 reverse** input has no function if the **HDMI input*** is defined as the rear-view camera input (Dip 5 = **ON**).

* **HDMI input only available with HDV-CR2**



3 Operating the video interface

The external keypad can be used to switch between all activated inputs.

➤ Long press of the keypad (2-3 seconds)

When pressed and held (2-3 seconds), the external keypad switches from the factory video to the first activated interface video input. Each additional long press switches to the next activated interface video input until the last one is reached, at which point it switches back to the factory video. Deactivated inputs are skipped. If all inputs are activated via the corresponding dip switch, the order is as follows:

Factory video → HDMI → V1-Left → V2-Right → V4-Reverse** → Factory video*

* **HDMI input only available with HDV-PSAAIO**

****V4 Reverse** can only be selected via the external keypad if the "External SW" function is set to "Yes" in the **V4 Reverse** menu

➤ Short press of the keypad (only possible if Dip 3 is set to ON)

When pressed briefly, the external keypad switches from the current video mode to the front camera input **V3-Front** and returns to the previous video mode when pressed again briefly.

Note: Even if the keypad is not needed to switch between multiple sources, it is strongly recommended that the keypad be connected and remain hidden on the interface. The keypad should not be installed in a "pressed" position.



3.1 Optional: Operating the video interface via the "HDA-RC" remote control

Instead of the external keypad, the interface can also be operated via the optionally available "HDA-RC" remote control.* This allows direct selection of the video/camera inputs and more convenient changing of the settings in the respective OSD menus.



"HDA-RC" remote control
optionally available

* The remote control is compatible with all HDA and HDV interfaces that are marked with "RC" at the end of the software version.

4 Specifications

BATT/ACC range	9V - 16V
Stand-by power drain	approx. 2.5mA
Power consumption	approx. 250mA @12V
Video input	0.7V - 1V
Video input signal types	FBAS/AHD/HDMI (HDV version only)
Signal standards FBAS/AHD	NTSC/PAL
Temperature range	-40°C to +85°C
Interface box dimensions	117 x 25 x 97 mm (W x H x D)
Dimensions of daughter PCB	60 x 5 x 70 mm (W x H x D)

5 FAQ - Troubleshooting interface functions - product-specific

Problem	Possible cause	Solution
Malfunction or no picture	Video input signal type for video source not defined in the OSD of the respective video input	See chapter 2.13 <i>settings OSD menu</i> - menu of the respective input



6 FAQ - Troubleshooting Interface functions - general

For any troubles which may occur, check the following table for a solution before requesting support from your vendor.

Symptom	Possible reason	Possible solution
No picture/black picture (factory picture).	Not all connectors have been reconnected to factory head-unit or monitor after installation.	Connect missing connectors.
	CAN-bus wires connected to CAN-bus in wrong place.	Refer to the manual where to connect to the CAN-bus. If not mentioned, try another place to connect to the CAN-bus.
	No power on video-interface (all LED video-interface are off).	Check power connection of interface.
No picture/black picture/white picture (inserted picture) but factory picture is OK.	No picture from video source.	Check on other monitor whether video source is OK.
	No video-source connected to the selected interface input.	Check settings dips 1 to 5 of 8dip bench of video interface which inputs are enabled and switch to corresponding input(s).
	Setting of video signal type of active video input is not equal to video signal type of connected video-source.	Set the video signal type of the video source correctly in the OSD menu of the corresponding input.
	LVDS cables plugged in wrong place.	Double-check whether order of LVDS cables is exactly connected according to manual. Plugging into head-unit does not work when the manual says to plug into monitor and vice versa.
Inserted picture totally wrong size or position.	Wrong settings of video-interface.	Verify the vehicle-specific dip switch position in the instructions. If necessary, test different positions of the vehicle-specific dip switches. Perform a power reset after each change (briefly remove the black 10-pin micro-fit power socket once).
Inserted picture double or multiple times on monitor.		
Inserted picture distorted, flickering or running vertically.	Video sources output set to AUTO or MULTI which causes a conflict with the interfaces auto detection.	(Only concerns video-sources with selectable output – e.g., DVD-Players, TV-Tuners, etc.) Set video source output fixed to PAL or NTSC. It is best to set all video sources to the same video signal type output.
	If error occurs only after source switching: Connected sources are not set to same video signal type output.	Set all video sources to the same video signal type output.
Inserted picture b/w.	Setting of video signal type of active video input is not equal to video signal type of connected video-source.	Set the video signal type of the video source correctly in the OSD menu of the corresponding input.

Symptom	Possible reason	Possible solution
Only on first inserted video activation after IGN on, the inserted picture is distorted.	Menu item <i>Trigger</i> of the corresponding video-input is set to <i>CAN-bus</i> though analogue signal triggering is used.	Open OSD-menu of corresponding video input and set the menu item <i>Trigger</i> to <i>Wire</i> .
Inserted picture qual. bad.	Picture settings have not been adjusted.	Use the 3 switches on interface-box or optional HDA-RC cable remote control to set the desired picture settings for the respective video source in the OSD menu of the interface.
Inserted picture size slightly wrong.		
Inserted picture position wrong.		
Camera input picture flickers.	Camera is being tested under fluorescent light (neon).	Test camera under natural light outside the garage.
Camera input picture is bluish.	Protection sticker not removed from camera lens.	Remove protection sticker from lens.
Camera input picture black.	Camera power taken directly from reverse gear lamp.	Use relay or electronic filter to "clean" reverse gear lamp power. Alternatively, camera power can be taken from green wire CAM Power.
Camera input picture has distortion.		
Switching to inserted video does not work after IGN on or vehicle startup- temporary.	Interface has a start-up delay during which, after interface start-up for certain time, there is no switching to inserted video. Required to prevent the factory system from crashing.	In OSD menu of V4, default delay can be shortened time in menu item <i>StartDelay</i> , this might especially make sense on installations without connection to CAN-bus. Note: Too short <i>StartDelay</i> setting can cause (sporadically) black-screen of factory picture or loss of factory touch-screen control.
Not possible to switch video sources by OEM button.	Function not supported in this vehicle.	Use external keypad for AV-switching.
Not possible to switch video sources by external keypad.	Pressed too short.	For video source switching a longer press of about 2.5 seconds is required.
	Video-input is not enabled.	Enable corresponding inputs (dips 1 to 5 of 8dip bench).
Interface does not switch to reverse camera input when reverse gear is engaged or does not switch to side camera input(s) when turn signal in on.	CAN-bus of vehicle not fully compatible with interface. Function not supported.	Follow the manual for R-gear signal or turn signal from analogue signal.
	Menu item <i>trigger</i> in the OSD of the video-input was set to <i>Wire</i> .	Switch on corresponding input by external button or 12V to corresponding trigger input. Open OSD-menu of corresponding video input and set the menu item <i>Trigger</i> to <i>CAN bus</i> .
OSD-menu of interface cannot be accessed/opened.	No inserted video input of interface is active, factory picture is displayed.	Each video input of interface has its own OSD with its own settings. The OSD for each input can only be opened when the input is displayed.



10R-06 5485



Made in China



